



Device Test Application Specification

for NFC Digital Protocol
and NFC Forum Type 1/2/3/4 Tags

NFC Forum™

DTA 1.2.2

NFCForum-CS-DeviceTestApplication

2012-02-04

RESTRICTIONS ON USE

This specification is copyright © 2005-2011 by the NFC Forum, and was made available pursuant to a license agreement entered into between the recipient (Licensee) and NFC Forum, Inc. (Licensor) and may be used only by Licensee, and in compliance with the terms of that license agreement (License). If you are not the Licensee, you may read this Specification, but are not authorized to implement or make any other use of this specification. However, you may obtain a copy of this Specification and implementation rights at the following page of Licensor's website: http://www.nfc-forum.org/specs/spec_license after entering into and agreeing to such license terms as Licensor is then requiring. On the date that this specification was downloaded by Licensee, the non-implementation terms of that license were as follows:

1. LICENSE GRANT.

Licensor hereby grants Licensee the right, without charge, to copy (for internal purposes only, except with respect to the elements listed on Exhibit A) and share this Specification with Licensee's members, employees and (to the extent related to Licensees' use of this Specification) consultants. This license grant does not include the right to sublicense, modify or create derivative works based upon any portion of the Specification, except for the elements listed in Exhibit A.

2. NO WARRANTIES.

THE SPECIFICATION IS PROVIDED "AS IS", WITHOUT WARRANTY OF ANY KIND, EXPRESS OR IMPLIED, INCLUDING BUT NOT LIMITED TO WARRANTIES OF MERCHANTABILITY, FITNESS FOR A PARTICULAR PURPOSE, ACCURACY, COMPLETENESS AND NONINFRINGEMENT OF THIRD PARTY RIGHTS. IN NO EVENT SHALL LICENSOR, ITS MEMBERS OR ITS CONTRIBUTORS BE LIABLE FOR ANY CLAIM, OR ANY DIRECT, SPECIAL, INDIRECT OR CONSEQUENTIAL DAMAGES, OR ANY DAMAGES WHATSOEVER RESULTING FROM LOSS OF USE, DATA OR PROFITS, WHETHER IN AN ACTION OF CONTRACT, NEGLIGENCE OR OTHER TORTIOUS ACTION, ARISING OUT OF OR IN CONNECTION WITH THE USE OR PERFORMANCE OF THE SPECIFICATION.

3. THIRD PARTY RIGHTS.

Without limiting the generality of Section 2 above, LICENSOR ASSUMES NO RESPONSIBILITY TO COMPILE, CONFIRM, UPDATE OR MAKE PUBLIC ANY THIRD PARTY ASSERTIONS OF PATENT OR OTHER INTELLECTUAL PROPERTY RIGHTS THAT MIGHT NOW OR IN THE FUTURE BE INFRINGED BY AN IMPLEMENTATION OF THE SPECIFICATION IN ITS CURRENT, OR IN ANY FUTURE FORM. IF ANY SUCH RIGHTS ARE DESCRIBED ON THE SPECIFICATION, LICENSOR TAKES NO POSITION AS TO THE VALIDITY OR INVALIDITY OF SUCH ASSERTIONS, OR THAT ALL SUCH ASSERTIONS THAT HAVE OR MAY BE MADE ARE SO LISTED.

4. TERMINATION OF LICENSE.

In the event of a breach of this Agreement by Licensee or any of its employees or members, Licensor shall give Licensee written notice and an opportunity to cure. If the breach is not cured within thirty (30) days after written notice, or if the breach is of a nature that cannot be cured, then Licensor may immediately or thereafter terminate the licenses granted in this Agreement.

5. MISCELLANEOUS.

All notices required under this Agreement shall be in writing, and shall be deemed effective five days from deposit in the mails. Notices and correspondence to the NFC Forum address as it appears below. This Agreement shall be construed and interpreted under the internal laws of the United States and the Commonwealth of Massachusetts, without giving effect to its principles of conflict of law.

NFC Forum, Inc.
401 Edgewater Place, Suite 600
Wakefield, MA, USA 01880

Contents

| | | |
|----------|---|-----------|
| 1 | Introduction..... | 1 |
| 1.1 | Scope..... | 1 |
| 1.2 | Audience..... | 1 |
| 1.3 | Applicable Documents or References | 1 |
| 1.4 | Administration..... | 3 |
| 1.5 | Name and Logo Usage | 3 |
| 1.6 | Intellectual Property | 4 |
| 1.7 | Special Word Usage | 4 |
| 1.8 | Requirement Numbering | 4 |
| 1.9 | Notational Conventions..... | 6 |
| 1.9.1 | Notations..... | 6 |
| 1.9.2 | Figures | 6 |
| 1.10 | Abbreviations | 8 |
| 1.11 | Glossary..... | 9 |
| 2 | Test Architecture Overview | 10 |
| 3 | General Requirements for Device Test Application | 11 |
| 4 | Test Profile and Listen Mode Execution..... | 12 |
| 4.1 | Test Profile and Listen Mode Execution – Main Loop..... | 13 |
| 4.2 | Configuration Parameters..... | 13 |
| 4.3 | Poll Mode Resolution Process..... | 24 |
| 4.3.1 | Poll Mode Resolution Process – Main Flow..... | 25 |
| 4.3.2 | NFC-A Communication..... | 27 |
| 4.3.3 | NFC-B Communication..... | 31 |
| 4.3.4 | NFC-F Communication | 33 |
| 4.3.5 | T1T Data Exchange | 34 |
| 4.3.6 | T2T Data Exchange | 35 |
| 4.3.7 | T3T Data Exchange | 36 |
| 4.3.8 | T4T Data Exchange | 36 |
| 4.3.9 | NFC-DEP Data Exchange | 37 |
| 4.4 | Listen Mode..... | 38 |
| 4.5 | Exception Processing..... | 38 |
| 5 | Test Transaction Functionalities in Poll Mode..... | 39 |
| 5.1 | Test Architecture in Poll Mode | 39 |
| 5.1.1 | Loop-back Test Functionality in Poll Mode..... | 39 |
| 5.1.2 | Type Tag Platform Test Functionality in Poll Mode..... | 40 |
| 5.1.3 | Type Tag Operation Test Functionality in Poll Mode..... | 41 |
| 5.2 | NFC-DEP Test Functionality in Poll Mode | 42 |
| 5.2.1 | NFC-DEP Test Functionality PATTERN_NUMBER Value..... | 42 |
| 5.2.2 | NFC-DEP Loop-back Functionality in Poll Mode | 42 |
| 5.3 | Type 1 Tag Test Functionality in Poll Mode..... | 44 |
| 5.3.1 | Type 1 Tag Test Functionality PATTERN_NUMBER Value | 44 |
| 5.3.2 | Type 1 Tag Platform Test Functionality..... | 44 |
| 5.3.3 | Type 1 Tag Operation NDEF Read Test Functionality | 44 |
| 5.3.4 | Type 1 Tag Operation NDEF Write Test Functionality | 45 |
| 5.3.5 | Type 1 Tag Operation Transition from READ/WRITE to READ-ONLY Functionality | 45 |

- 5.4 Type 2 Tag Test Functionality in Poll Mode..... 45
 - 5.4.1 Type 2 Tag Test Functionality PATTERN_NUMBER Value 46
 - 5.4.2 T2T Platform Test Functionality 46
 - 5.4.3 Type 2 Tag Operation NDEF Read Test Functionality 46
 - 5.4.4 Type 2 Tag Operation NDEF Write Test Functionality 47
 - 5.4.5 Type 2 Tag Operation Transition from READ/WRITE to READ-ONLY
Functionality 48
- 5.5 Type 3 Tag Test Functionality in Poll Mode..... 48
 - 5.5.1 Type 3 Tag Test Functionality PATTERN_NUMBER Value 48
 - 5.5.2 Type 3 Tag Operation Command Test with Minimum Number of Blocks .. 48
 - 5.5.3 Type 3 Tag Operation Command Test with Maximum Number of Services 49
 - 5.5.4 Type 3 Tag Operation Command Test with Maximum Number of Blocks . 50
 - 5.5.5 Type 3 Tag Operation NDEF Read Test Functionality 51
 - 5.5.6 Type 3 Tag Operation NDEF Write Test Functionality 51
- 5.6 Type 4 Tag Test Functionality in Poll Mode..... 53
 - 5.6.1 Type 4 Tag Test Functionality PATTERN_NUMBER Value 53
 - 5.6.2 Type 4A Tag and Type 4B Tag Loop-back Functionality in Poll Mode 53
 - 5.6.3 Type 4 Tag Operation NDEF Read Test Functionality 55
 - 5.6.4 Type 4 Tag Operation NDEF Write Test Functionality 55
- 6 Test Transaction Functionalities in Listen Mode.....56**
 - 6.1 Test Architecture in Listen Mode..... 56
 - 6.1.1 Loop-back Test Functionality in Listen Mode..... 56
 - 6.1.2 Type Tag Platform Test Functionality in Listen Mode..... 57
 - 6.2 NFC-DEP Test Functionality in Listen Mode..... 58
 - 6.2.1 NFC-DEP Test Functionality Requirement 58
 - 6.2.2 NFC-DEP Loop-back Functionality in Listen Mode..... 58
 - 6.3 Type 3 Tag Test Functionality in Listen Mode 60
 - 6.3.1 Type 3 Tag Test Functionality Requirement 60
 - 6.3.2 Type 3 Tag Basic Command Exchange Test Functionality in Listen Mode 60
 - 6.4 Type 4 Tag Test Functionality in Listen Mode 61
 - 6.4.1 Type 4 Tag Test Functionality Requirement 61
 - 6.4.2 Type 4A Tag and Type 4B Tag Loop-back Functionality in Listen Mode .. 61
 - 6.4.3 Type 4A Tag and Type 4B Tag Proprietary Functionality in Listen Mode.. 63
- A. Exhibit A..... 66**
- B. Values..... 67**
 - B.1 Timing Value..... 67
- C. PATTERN_NUMBER 68**
- D. Revision History 70**

Figures

- Figure 1: Example Flowchart 5
- Figure 2: Schematic View of the Test Environment (Informative Image)..... 10
- Figure 3: Test Profile and Listen Mode Execution Flowchart – Main Loop..... 13
- Figure 4: Test Profile – Poll Mode Resolution Process Flowchart – Main Flow 25

| | |
|--|----|
| Figure 5: Test Profile – Poll Profile Resolution Process Flowchart – NFC-A Communication ... | 27 |
| Figure 6: Test Profile – Poll Profile Resolution Process Flowchart – NFC-B Communication ... | 31 |
| Figure 7: Test Profile – Poll Profile Resolution Process Flowchart – NFC-F Communication.... | 33 |
| Figure 8: Test Profile – Poll Profile Resolution Process Flowchart – T1T Data Exchange..... | 35 |
| Figure 9: Test Profile – Poll Profile Resolution Process Flowchart – T2T Data Exchange..... | 35 |
| Figure 10: Test Profile – Poll Profile Resolution Process Flowchart – T3T Data Exchange..... | 36 |
| Figure 11: Test Profile – Poll Profile Resolution Process Flowchart – T4T Data Exchange..... | 36 |
| Figure 12: Test Profile – Poll Profile Resolution Process Flowchart – NFC-DEP Data Exchange | 37 |
| Figure 13: Loop-back Test Functionality in Poll Mode | 40 |
| Figure 14: Type Tag Platform Test Functionality in Poll Mode | 41 |
| Figure 15: Type Tag Operation Test Functionality in Poll Mode | 42 |
| Figure 16: NFC-DEP Loop-back Functionality in Poll Mode Flowchart | 43 |
| Figure 17: Type 4ATag and Type 4B Tag Loop-back Functionality in Poll Mode Flowchart..... | 54 |
| Figure 18: Loop-back Test Functionality in Listen Mode..... | 57 |
| Figure 19: Type Tag Platform Test Functionality in Poll Mode | 58 |
| Figure 20: NFC-DEP Loop-back Functionality in Listen Mode Flowchart..... | 59 |
| Figure 21: Type 4A Tag and Type 4B Tag Loop-back Functionality in Listen Mode Flowchart | 62 |
| Figure 22: T4AT and T4BT Proprietary Functionality in Listen Mode Flowchart..... | 65 |

Tables

| | |
|--|----|
| Table 1: Sample Requirement | 4 |
| Table 2: Example Requirements | 5 |
| Table 3: Notational Conventions..... | 6 |
| Table 4: Figure Notation | 7 |
| Table 5: Listen Mode – Configuration Parameters | 14 |
| Table 6: Technology Detection Activity – Configuration Parameters | 21 |
| Table 7: Collision Resolution Activity – Symbol 2 – Configuration Parameters | 22 |
| Table 8: Device Activation Activity – Configuration Parameters..... | 23 |
| Table 9: Test Profile – Configuration Parameters..... | 24 |
| Table 10: Revision History..... | 70 |

Requirements

| | |
|---|----|
| Requirements 1: Control of the IUT..... | 11 |
|---|----|

| | |
|---|----|
| Requirements 2: Test Profile and Listen Mode Execution – Main Loop | 13 |
| Requirements 3: Test Profile - Poll Mode Resolution Process – Main Flow | 26 |
| Requirements 4: Test Profile – Poll Profile Resolution Process – NFC-A Communication..... | 28 |
| Requirements 5: Test Profile – Poll Profile Resolution Process – NFC-B Communication..... | 32 |
| Requirements 6: Test Profile – Poll Profile Resolution Process – NFC-F Communication | 34 |
| Requirements 7: Test Profile – Poll Profile Resolution Process – T1T Data Exchange | 35 |
| Requirements 8: Test Profile – Poll Profile Resolution Process – T2T Data Exchange | 35 |
| Requirements 9: Test Profile – Poll Profile Resolution Process – T3T Data Exchange | 36 |
| Requirements 10: Test Profile – Poll Profile Resolution Process – T4T Data Exchange | 36 |
| Requirements 11: Test Profile – Poll Profile Resolution Process – NFC-DEP Data Exchange ... | 37 |
| Requirements 12: Listen Mode | 38 |
| Requirements 13: Exception Processing | 38 |
| Requirements 14: Type 2 Tag Test Functionalities..... | 42 |
| Requirements 15: NFC-DEP Loop-back Functionality in Poll Mode..... | 43 |
| Requirements 16: Type 1 Tag Test Functionalities..... | 44 |
| Requirements 17: Type 1 Tag Operation NDEF Read Test Functionality..... | 44 |
| Requirements 18: Type 1 Tag Operation NDEF Write Test Functionality..... | 45 |
| Requirements 19: Type 1 Tag Operation Transition from READ/WRITE to READ-ONLY Functionality..... | 45 |
| Requirements 20: Type 2 Tag Test Functionalities..... | 46 |
| Requirements 21: Type 2 Tag Platform Test Functionality | 46 |
| Requirements 22: Type 2 Tag Operation NDEF Read Test Functionality..... | 46 |
| Requirements 23: Type 2 Tag Operation NDEF Write Test Functionality..... | 47 |
| Requirements 24: Type 2 Tag Operation Transition from READ/WRITE to READ-ONLY Functionality..... | 48 |
| Requirements 25: Type 3 Tag Test Functionalities..... | 48 |
| Requirements 26: Type 3 Tag Operation NDEF Read Test Functionality..... | 51 |
| Requirements 27: Type 3 Tag Operation NDEF Write Test Functionality..... | 51 |
| Requirements 28: Type 4 Tag Test Functionalities..... | 53 |
| Requirements 29: Type 4A Tag and Type 4B Tag Loop-back Functionality in Poll Mode | 54 |
| Requirements 30: Type 4 Tag Operation NDEF Read Test Functionality..... | 55 |
| Requirements 31: Type 4 Tag Operation NDEF Write Test Functionality..... | 55 |
| Requirements 32: NFC-DEP Test Functionality in Listen Mode..... | 58 |
| Requirements 33: NFC-DEP Loop-back Functionality in Listen Mode | 60 |
| Requirements 34: Type 3 Tag Test Functionality in Listen Mode..... | 60 |

Requirements 35: Type 4 Tag Test Functionality in Listen Mode..... 61

Requirements 36: Type 4A Tag and Type 4B Tag Loop-back Functionality in Listen Mode..... 63

Requirements 37: Type 4A Tag and Type 4B Tag Proprietary Functionality in Listen Mode –
Generic Requirements 64

Requirements 38: T4AT and T4BT Proprietary Functionality in Listen Mode 65

1 Introduction

1.1 Scope

This specification describes the Device Test Application (DTA) that a vendor can integrate in an NFC Forum Device to ensure that the Implementation Under Test (IUT) can be tested against the NFC Digital Protocol Technical Specification [DIGITAL] and NFC Forum Type 1-4 Tag Operation Specifications [TnTOP].

The Test Laboratory uses the DTA to configure the IUT for NFC Forum Digital Certification Testing. The DTA, together with the NFC Digital Protocol Technical Specification and the NFC Forum Type 1-4 Tag Operation Specifications, provides all the information vendors need in order to implement in their devices the functionalities required to pass the NFC Forum Certification. The DTA has been designed to maximize automation with minimal human intervention and to minimize the resources needed when running the NFC Forum test cases.

The DTA is based on Profiles, which are explained in the NFC Activity Specification ([ACTIVITY]). A Profile is a set of activities (i.e., a sequence of commands and responses) with a set of configuration parameters. The combination of Activities and Profiles defines a predictable, deterministic behavior for an NFC Forum Device, which is exploited by the DTA to guarantee that the test cases can be reliably reproduced and to reduce the resources (in term of memory space) needed by the DTA itself.

This document specifies a Test Profile and Listen Mode Execution based on [ACTIVITY]. The Test Profile and Listen Mode Execution are integrated into the DTA together with transaction functionalities, which are specific command sequences or well-known Type Tag operations that are under test.

1.2 Audience

This document is intended for use by vendors that want to certify an NFC Forum Device.

1.3 Applicable Documents or References

This document complements NFC Forum Digital Test Cases.

| | |
|--------------|---|
| [ACTIVITY] | NFC Activity Specification, Version 1.0, NFC Forum |
| [DIGITAL] | NFC Digital Protocol, Version 1.0, NFC Forum |
| [DIGITAL_TC] | Test Cases for the NFC Digital Protocol and NFC Activity, October 2011, NFC Forum |
| [ICS] | Implementation Conformance Statement (ICS), October 2011, NFC Forum |

- [ISO/IEC_9646] ISO/IEC 9646,
Open Systems Interconnection – Conformance testing methodology and framework,
1995,
ISO/IEC
- [ISO/IEC_9646-1] ISO/IEC 9646-1:
Information Technology – Open Systems Interconnection –
Conformance testing methodology and framework – Part 1: General concepts
1994,
ISO
- [ISO/IEC_9646-2] ISO/IEC 9646-2:
Information Technology – Open Systems Interconnection –
Conformance testing methodology and framework – Part 2: Abstract Test Suite specification
1994,
ISO
- [ISO/IEC_14443] Identification cards – Contactless integrated circuit cards – Proximity cards
Includes:
[ISO/IEC 14443-1:2008], Identification cards – Contactless integrated circuit cards – Proximity cards – Part 1: Physical characteristics
[ISO/IEC 14443-2:2010], Identification cards – Contactless integrated circuit cards – Proximity cards – Part 2: Radio frequency power and signal balance
[ISO/IEC 14443-3:2001], Identification cards – Contactless integrated circuit cards – Proximity cards – Part 3: Initialization and anticollision
[ISO/IEC_14443-3:2001/Amd.1], Identification cards -- Contactless integrated circuit(s) cards -- Proximity cards -- Part 3: Initialization and Anti-collision, 1 February 2001 with Amendment 1: Bit rates of fc/64, fc/32 and fc/16, 15 June 2005; Amendment 3: Handling of reserved fields and values, 22 March 2006; and Corrigendum 1: Amendment 1 - Corrigendum, 29 August 2006
[ISO/IEC 14443-4:2008], Identification cards – Contactless integrated circuit cards – Proximity cards – Part 4: Transmission protocol
ISO/IEC
- [IXIT] Implementation eXtra Information for Testing (IXIT),
October 2011,
NFC Forum
- [RFC2119] Key words for use in RFCs to Indicate Requirement Levels, RFC 2119,
S. Bradner,
March 1997,
Internet Engineering Task Force
- [T1TOP] Type 1 Tag Operation Specification
Version 1.1,
NFC Forum

| | |
|------------|--|
| [T2TOP] | Type 2 Tag Operation, Version 1.1 NFC Forum |
| [T3TOP] | Type 3 Tag Operation, Version 1.1, NFC Forum |
| [T4TOP] | Type 4 Tag Operation, Version 2.0, NFC Forum |
| [TC-T1TOP] | Test Cases for Type 1 Tag Operation, October 2011, NFC Forum |
| [TC-T2TOP] | Test Cases for Type 2 Tag Operation, October 2011, NFC Forum |
| [TC-T3TOP] | Test Cases for Type 3 Tag Operation, October 2011, NFC Forum |
| [TC-T4TOP] | Test Cases for Type 4 Tag Operation, October 2011, NFC Forum |

1.4 Administration

The Device Test Application Specification is an open specification supported by the Near Field Communication Forum, Inc., located at:

401 Edgewater Place, Suite 600
Wakefield, MA, 01880

Tel.: +1 781-876-8955

Fax: +1 781-610-9864

<http://www.nfc-forum.org/>

The Testing Working Group maintains this specification.

1.5 Name and Logo Usage

The Near Field Communication Forum's policy regarding the use of the trademarks *NFC Forum* and the NFC Forum logo is as follows:

- Any company MAY claim compatibility with NFC Forum specifications, whether a member of the NFC Forum or not.
- Permission to use the NFC Forum logos is automatically granted to designated members only as stipulated on the most recent Membership Privileges document, during the period of time for which their membership dues are paid.
- Member's distributors and sales representatives MAY use the NFC Forum logo in promoting member's products sold under the name of the member.

- The logo SHALL be printed in black or in color as illustrated on the Logo Page that is available from the NFC Forum at the address above. The aspect ratio of the logo SHALL be maintained, but the size MAY be varied. Nothing MAY be added to or deleted from the logos.
- Since the NFC Forum name is a trademark of the Near Field Communication Forum, the following statement SHALL be included in all published literature and advertising material in which the name or logo appears:

NFC Forum and the NFC Forum logo are trademarks of the Near Field Communication Forum.

1.6 Intellectual Property

The Device Test Application Specification conforms to the Intellectual Property guidelines specified in the NFC Forum's *Intellectual Property Rights Policy*, as outlined in the NFC Forum *Rules of Procedure*. These documents are available on the [NFC Forum website](#).

1.7 Special Word Usage

The key words “MUST”, “MUST NOT”, “REQUIRED”, “SHALL”, “SHALL NOT”, “SHOULD”, “SHOULD NOT”, “RECOMMENDED”, “MAY”, and “OPTIONAL” in this document are to be interpreted as described in [RFC2119].

1.8 Requirement Numbering

Requirements in this document are uniquely numbered, with the number appearing next to each requirement. Requirements can include informative statements. In this case, the statement is formatted with italics and MAY instead of MUST is used. For example:

Table 1: Sample Requirement

1.8.1.1 A car MUST have four wheels.

A car MAY have five wheels.

A figure that is labeled “flowchart” illustrates the behavior given by the corresponding requirements tables. Figures are informative if not otherwise stated. Figure 1 shows an example.

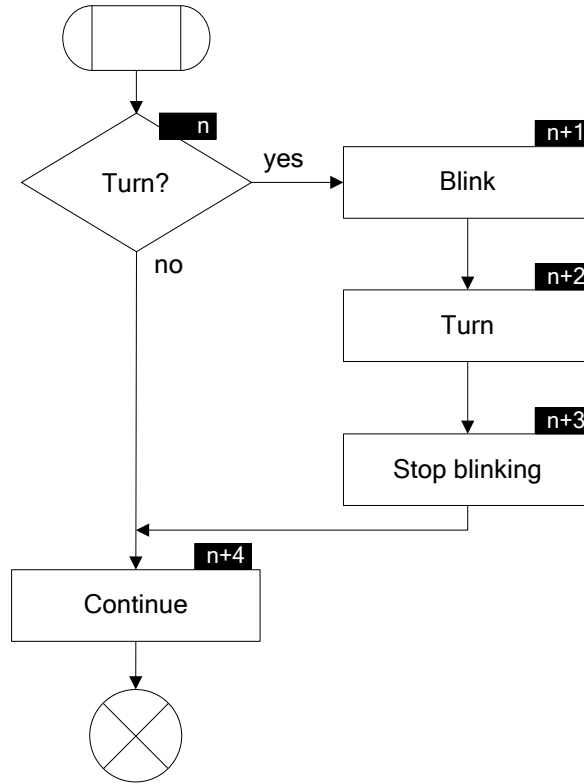

Figure 1: Example Flowchart

A requirement can be labeled as a symbol when referring to a flowchart, indicating a particular sequence. If the current requirement is labeled “Symbol *n*”, then the next requirement in the sequence is “Symbol *n+1*”, unless explicitly stated differently.

Table 2: Example Requirements

| | |
|---------|---|
| 1.8.1.2 | Symbol <i>n</i> If a car wants to turn left or right, it MUST proceed to Symbol <i>n+1</i> . Otherwise, the car MUST proceed to Symbol <i>n+4</i> . |
| 1.8.1.3 | Symbol <i>n+1</i> The car MUST blink. |
| 1.8.1.4 | Symbol <i>n+2</i> The car MUST turn. |
| 1.8.1.5 | Symbol <i>n+3</i> The car MUST stop blinking. |
| 1.8.1.6 | Symbol <i>n+4</i> The car MUST continue to drive straight ahead or stop. |

1.9 Notational Conventions

1.9.1 Notations

Table 3 defines the notational conventions used in this document.





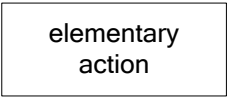
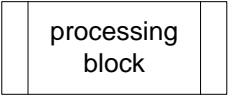

Table 3: Notational Conventions

| Notation | Description |
|--------------|---|
| XYh | Hexadecimal notation. Values expressed in hexadecimal form are followed by a lower case “h”. For example, 27509 decimal is expressed in hexadecimal as 6B75h. |
| xyb | Binary notation. Values expressed in binary form are followed by a lower case “b”. For example, 82h hexadecimal is expressed in binary as 10000010b. |
| [...] | Optional part |
| xx | More than one value possible |
| STATE | Written in COURIER FONT and in bold to distinguish them from the text. |
| PARAMETER | Written in CAPITAL LETTERS to distinguish it from the surrounding text. |
| CON_ | Prefix for Configuration Parameters; e.g., CON_DEVICES_LIMIT. |
| INT_ | Prefix for variables used in the Activities; e.g., INT_COLL_PEND. |
| GRE_ | Prefix for variables used in the Greedy Collection; e.g., GRE_POLL_A. |

1.9.2 Figures

Table 4 defines the graphical notation used in the figures of this document.

Table 4: Figure Notation

| Symbol | Meaning |
|--|--|
|  Activity | Activity |
|  | Start of a flowchart |
|  label | Connection point with dedicated label. Used when a flowchart is split into multiple figures |
|  | End of a flowchart |
|  test | Test block with one input branch and several output branches |
|  elementary action | Elementary action block |
|  processing block | Processing block that can be decomposed in elementary action blocks and/or other processing blocks |
|  | Connecting element with processing flow indicated by the direction of the arrow |

1.10 Abbreviations

| Abbreviation | Description |
|--------------|---|
| APDU | Application Protocol Data Unit |
| C-APDU | Command APDU |
| DUT | Device Under Test |
| IUT | Implementation Under Test |
| n.a. | Not Applicable |
| NDEF | NFC Data Exchange Format |
| NFC | Near Field Communication |
| NFC-A | Near Field Communication – Type A Technology |
| NFC-B | Near Field Communication – Type B Technology |
| NFC-F | Near Field Communication – Type F Technology |
| NFCID0 | NFC-B identifier. NFCID0 is always 4 long. |
| NFCID1 | NFC-A identifier of the NFC Forum Device in the Passive Communication mode. NFCID1 can be 4, 7, or 10 bytes long (simple, double, or triple size). |
| NFCID2 | NFC-F identifier of the NFC Forum Device in the Passive Communication mode. NFCID2 is always 8 bytes long. |
| NFCID3 | NFCIP-1 identifier of the NFC Forum Device. NFCID3 is always 10 bytes long. |
| PDU | Protocol Data Unit |
| R-APDU | Response APDU |
| RF | Radio Frequency (RF field = magnetic field) |
| SC | System Code, NFC-F |
| T1T | Type 1 Tag Platform |
| T2T | Type 2 Tag Platform |
| T3T | Type 3 Tag Platform |
| T4AT | Type 4A Tag Platform |
| T4BT | Type 4B Tag Platform |
| T4T | Type 4 Tag Platform |

1.11 Glossary

Device Test Application (DTA)

Test application developed by the Vendor. It allows control and observation of the exchanges between the IUT and the Lower Tester.

Device Under Test (DUT)

NFC Forum Device that contains the Implementation Under Test (IUT).

Digital Certification Testing

A defined set of tests that checks the software responsible for the data exchange between an NFC Forum Device and another NFC Forum Device or tag. The tests check the [DIGITAL] and [ACTIVITY].

Implementation Under Test (IUT)

Part of the DUT that is used for the NFC Forum Certification Test. In digital testing, IUT is the layer that corresponds to the [DIGITAL] and [ACTIVITY] specifications, embedded in an NFC Forum Device provided for NFC Forum Digital Certification Testing.

ISO-DEP Protocol

The half-duplex block transmission protocol as defined in [DIGITAL].

Lower Tester (LT)

Test tool that allows control and observation of the tested protocol.

NFC-DEP

The half-duplex block transmission protocol as defined in [DIGITAL].

Test Environment

Test environment required to perform NFC Forum Digital Certification Testing. It includes the Device Test Application (DTA), Implementation Under Test (IUT), and the Lower Tester (LT).

Test Functionalities

Functionalities to be implemented by the vendor following the requirements specified in this document, and to be implemented in the Device Test Application to allow the Test Laboratory to proceed to Digital Certification Testing.

Test Laboratory

A facility approved by the NFC Forum to perform NFC Forum Digital Certification Testing.

Vendor

Entity that submits the NFC Device for NFC Forum Digital Certification Testing.

2 Test Architecture Overview

NFC Forum requires that devices implementing [DIGITAL] and [ACTIVITY] and submitted for NFC Forum Certification are tested against the relevant specifications.

To test the compliance of the implementation against [DIGITAL] and [ACTIVITY], NFC Forum Devices have to be tested in a defined Test Environment. See Figure 2.

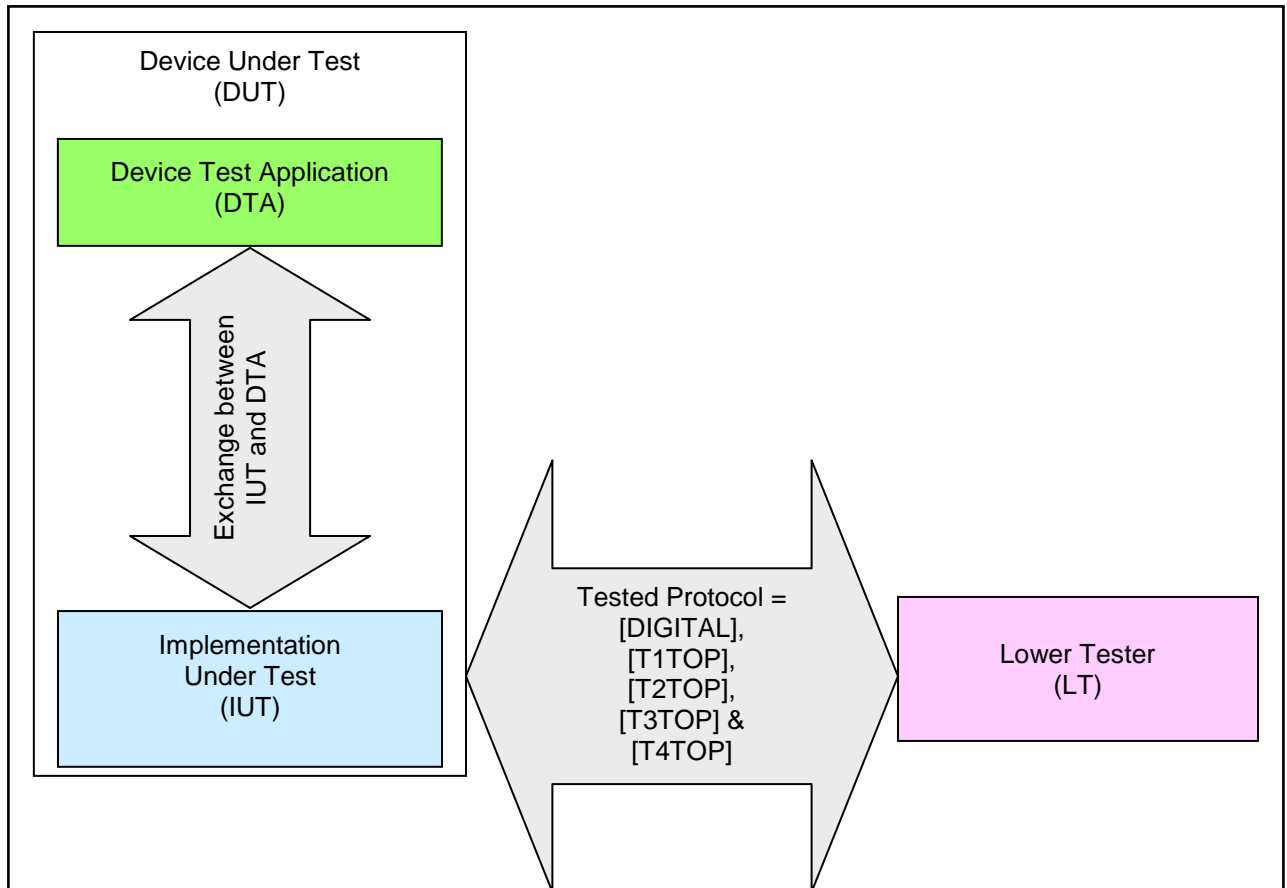

Figure 2: Schematic View of the Test Environment (Informative Image)

The Test Environment is composed of two parts:

- LT: Lower Tester
- DUT with Device Test Application or DUT connected to the external Device Test Application (e.g., PC with DTA connected to the NFC Forum Device)

This document describes the requirements the Device Test Application must comply with and is structured as described below:

- Section 3: General Requirements for Device Test Application
- Section 4: Test Profile and Listen Mode Execution
- Section 5: Test Transaction Functionalities in Poll Mode
- Section 6: Test Transaction Functionalities in Listen Mode

3 General Requirements for Device Test Application

The Device Test Application complies with the following general requirements.

Requirements 1: Control of the IUT

| | |
|---------|---|
| 3.1.1.1 | The Device Test Application MUST execute the Test Profile and Listen Mode Execution (see Section 4) and the Test Functionalities (see Section 5 and Section 6) as indicated in [IXIT] and in accordance with the Implementation Conformance Statement (see [ICS]). |
| 3.1.1.2 | The Test Application MUST permit the Test Profile and Listen Mode Execution to select, start, and stop(see Section 4). The DTA MUST permit the Test Functionalities to select, start, and stop (see Section 5 and Section 6). |

4 Test Profile and Listen Mode Execution

The Test Profile defines a sequence of Activities to be performed by the NFC Forum Device. The Test Profile consists of an initialization, a Resolution Process (called Poll Mode Resolution Process), Configuration Parameters, Activities, the Greedy Collection, and a Clean-up (see [ACTIVITY], Section 8).

During Test Profile initialization, the Configuration Parameters as needed by the included Activities are set and RF Collision Avoidance takes place (see [ACTIVITY], Section 7, Poll Mode – RF Collision Avoidance).

The Test Profile Clean-up erases the Greedy Collection and the Operating Field is turned to the Operating Field Off state (see [ACTIVITY], Section 6, Requirement 6.1.1.1).

The Poll Mode Resolution Process consists of an algorithm that is controlled by the DTA and determines the next Activity to call, depending on the outcome of the previous Activity. For each possible Activity to call next, the Resolution Process provides the necessary input parameters.

In the DTA, the Test Profile enables the NFC Forum Device to connect to the LT and to establish the transport communication protocols: NFC-DEP transport protocol, Type 4A and 4B Tag Half-duplex protocol, and Type 1-3 Tag platform protocol. Eventually, the transport communication protocol is used by the transaction functionalities described in Section 5 and Section 6 and by the test cases related to [T1TOP], [T2TOP], [T3TOP], and [T4TOP].

The Test Profile is combined with Listen Mode to create the Test Profile and Listen Mode Execution, which is part of the functionality of the Device Test Application (DTA).

The Test Profile and Listen Mode Execution has been designed to allow maximum automation of the testing process and minimum human intervention when running the test cases, and also to allow the flexibility needed to support different implementation options as indicated in the ICS (see [ICS]).

Depending on which devices are discovered, the Test Profile allows an NFC-DEP communication to be established to the LT executing either the Poll Mode Digital Protocol Test Cases [DIGITAL_TC] or the NFC Forum Type Tag Test Cases [TC-T1TOP], [TC-T2TOP], [TC-T3TOP], and [TC-T4TOP].

Listen Mode is the counterpart for Poll Mode. Listen Mode assumes the NFC Forum Device has activated support for NFC-DEP, ISO-DEP (on NFC-A and NFC-B), and Type 3 Tag emulation. If only a subset of this functionality is supported, the corresponding part of the Listen Mode state machine is deactivated.

4.1 Test Profile and Listen Mode Execution – Main Loop

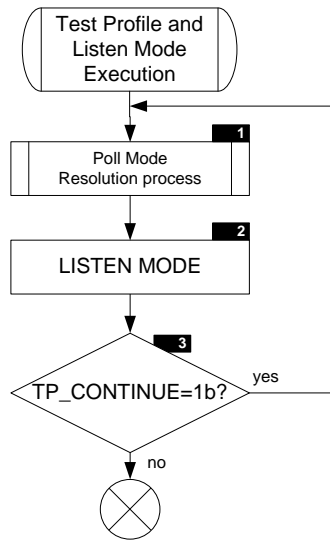

Figure 3: Test Profile and Listen Mode Execution Flowchart – Main Loop

Requirements 2: Test Profile and Listen Mode Execution – Main Loop

| | |
|---------|--|
| 4.1.1.1 | <p>Symbol 1:</p> <p>The NFC Forum Device MUST enter Poll Mode according to [ACTIVITY] (see [ACTIVITY], Sections 6, 8, and 9) and MUST proceed to Section 4.3.</p> |
| 4.1.1.2 | <p>Symbol 2:</p> <p>After a time equal to $T_{\text{TRANSITION_PM} \rightarrow \text{LM}}$ from when the Operating Field is switched to the Operating Field Off state, the NFC Forum Device MUST enter Listen Mode according to the [ACTIVITY] (see [ACTIVITY], Sections 3, 4, and 5) and MUST proceed to Section 4.4.</p> |
| 4.1.1.3 | <p>Symbol 3:</p> <p>If the NFC Forum Device is configured to continue (i.e., TP_CONTINUE has a value equal to 1), then the NFC Forum Device MUST proceed to Symbol 1. Otherwise, the NFC Forum Device MUST exit.</p> |

NOTE $T_{\text{TRANSITION_PM} \rightarrow \text{LM}}$ value is indicated in [IXIT]. After the $T_{\text{TRANSITION_PM} \rightarrow \text{LM}}$, the LT can switch the Operating Field to the Operating Field On state to communicate with the NFC Forum Device.

4.2 Configuration Parameters

The Test Profile and Listen Mode Execution has a set of configuration parameters. The parameters belong either to the activities, to the Test Profile itself, or to Listen Mode. The settings of these parameters depend on the involved activities (see [ACTIVITY], this document, [IXIT], and [ICS]).

Table 5, Table 6, Table 7, Table 8, Table 9, and show the Activity and the Test Profile and Listen Mode Execution parameters and their settings related to a PATTERN_NUMBER equal to '0000'. With a PATTERN_NUMBER different from '0000', the configuration parameters can change as indicated in Section 5 and Section 6.

If a parameter depends on information from [IXIT] or [ICS], this is directly indicated.

Table 5: Listen Mode – Configuration Parameters

| Name | Value | Format | Size | Description |
|------------------|--------------------------|--------|-------|---|
| CON_LISTEN_DEP_A | 1b | Binary | 1 bit | <p>This parameter controls whether to listen for NFC-A Technology with NFC_DEP support or not.</p> <p>1b: Listen for NFC-A Technology with NFC-DEP support</p> <p>0b: Do not listen for NFC-A Technology with NFC_DEP support</p> |
| CON_LISTEN_DEP_F | 0b or 1b, see Appendix C | Binary | 1 bit | <p>This parameter controls whether to listen for NFC-F Technology with NFC_DEP support or not.</p> <p>1b: Listen for NFC-F Technology with NFC-DEP support</p> <p>0b: Do not listen for NFC-F Technology with NFC-DEP support</p> |

| Name | Value | Format | Size | Description |
|------------------|-----------------------------|--------|-------|---|
| CON_LISTEN_T3TP | 0b or 1b, see Appendix C | Binary | 1 bit | <p>This parameter controls whether to listen for NFC-F Technology with Type 3 Tag Platform support or not.</p> <p>1b: Listen for NFC-F Technology with Type 3 Tag Platform support</p> <p>0b: Do not listen for NFC-F Technology with Type 3 Tag Platform support</p> |
| CON_LISTEN_T4ATP | 0b or 1b , defined in [ICS] | Binary | 1 bit | <p>This parameter controls whether to listen for NFC-A Technology with Type 4 Tag Platform support or not.</p> <p>1b: Listen for NFC-A Technology with Type 4 Tag Platform support</p> <p>0b: Do not listen for NFC-A Technology with Type 4 Tag Platform support</p> |

| Name | Value | Format | Size | Description |
|------------------|--|-------------------------|-----------------------|---|
| CON_LISTEN_T4BTP | 0b or 1b , defined in [ICS] | binary | 1 bit | <p>This parameter controls whether to listen for NFC-B Technology with Type 4 Tag Platform support or not.</p> <p>1b: Listen for NFC-B Technology with Type 4 Tag Platform support</p> <p>0b: Do not listen for NFC-B Technology with Type 4 Tag Platform support</p> |
| CON_ADV_FEAT | 0b | Binary | 1 bit | <p>1b: Support advanced protocol features</p> <p>0b: Do not support advanced protocol features</p> |
| CON_SYS_CODE [2] | CON_SYS_CODE [0] = 'FFFF' CON_SYS_CODE [1] = '12FC' | Array of byte Sequences | 2 bytes x 2 = 4 bytes | <p>If configured for Type 3 Tag Platform, an ordered list of N system codes is maintained by the adjacent upper layer ($N > 0$). Otherwise, the list contains a single system code of value FFFFh as a default value ($N = 1$).</p> |

| Name | Value | Format | Size | Description |
|-------------------|---|-------------------------------|-------------------------------|--|
| CON_SENSF_RES [2] | <p>CON_SENSF_RES [0] = '01FE UUUUUUUUUU UU(NFCID2)' + 'UUUU(PAD0)' + 'UUUUUU(PAD1)' + 'UU(MRTI_{CHECK})' + 'UU(MRTI_{UPDATE})' ' + 'UU(PAD2)'</p> <p>CON_SENSF_RES [1] = '02FE UUUU UUUUUUUU(NF CID2)' + 'UUUU(PAD0)' + 'UUUUUU(PAD1)' + 'UU(MRTI_{CHECK})' + 'UU(MRTI_{UPDATE})' ' + 'UU(PAD2)'</p> <p>with 'UUUU' Any value</p> | Array of byte Sequences | 16 bytes x 2 = 32 bytes | <p>See SENSF_RES format in [DIGITAL].</p> <p>In particular:</p> <ul style="list-style-type: none"> • NFCID2 must be configured if the NFC Forum Device cannot generate random numbers • If configured for Type 3 Tag Platform, then PAD1, MRTI_{CHECK}, MRTI_{UPDATE}, and PAD2 must be configured as per [DIGITAL]. <p>Otherwise, these data elements can have any value.</p> |

| Name | Value | Format | Size | Description |
|-------------|--|-------------------------|----------|---|
| CON_ATR_RES | NFCID3 = 'U...U' Any value, BS _T ='00', BR _T ='00', TO =('0000uuuu') b, PP _T =('00uu00u0') b | Array of byte Sequences | variable | See ATR_RES Format in [DIGITAL]. In particular: <ul style="list-style-type: none"> • NFCID3_T must be configured if the NFC Forum Device cannot generate random numbers • BS_T, BR_T, TO, PP_T need to be configured • General bytes (G_{T0}...G_{Tn}) need to be configured if the upper adjacent layer wants to indicate some information such as LLCp support. |

| Name | Value | Format | Size | Description |
|---------|---|-------------------------|----------|------------------------------|
| CON_ATS | <p>TL = (number of Historical bytes + 5) and ('05'h ≤ TL ≤ ('14'h</p> <p>T0 = ("0111aaaa")b with ("aaaa")b = FSCI</p> <p>TA(1) = ('00'h or ('80'h</p> <p>TB(1) = ("XY")h with</p> <ul style="list-style-type: none"> • X = FWI where X ≤ ('7'h • Y = SFGI where Y ≤ ('8'h <p>TC(1) = ("000000uu")b where the bits indicated as 'u' may take any value.</p> <p>Historical bytes = up to 15 bytes (k ≤ 14) that may take any value.</p> | Array of byte Sequences | variable | See ATS format in [DIGITAL]. |

| Name | Value | Format | Size | Description |
|----------------|---|-------------------------|----------|--|
| CON_SENSB_RES | <p>Byte 1 of Protocol Info (Byte 10 of SENSB_RES) = ('00')h or ('80')h</p> <p>Byte 2 of Protocol Info (Byte 11 of SENSB_RES) =</p> <ul style="list-style-type: none"> • Most significant nibble = Max_Frame_Size where ('2')h ≤ Max_Frame_Size ≤ ('8')h • Least significant nibble = ('1')h <p>Byte 3 of Protocol Info (Byte 12 of SENSB_RES) =</p> <ul style="list-style-type: none"> • Most significant nibble = FWI where FWI ≤ ('7')h • Least significant nibble (ADC and FO) where <ul style="list-style-type: none"> • bit 4=0 • bit 3, bit 2, bit 1 = any value | Array of byte Sequences | variable | See SENSB_RES format in [DIGITAL]. |
| CON_ATTRIB_RES | '00' | Array of byte Sequences | variable | See ATTRIB Response in [DIGITAL], in particular MBLI. |
| CON_BITR_F | '06' | integer | 1 byte | b2=1: 212 kbps b3=1: 424 kbps At least one bit of these must be set. |

Table 6: Technology Detection Activity – Configuration Parameters

| Name | Value | Format | Size | Description |
|----------------|-----------------------------------|---------------|-------------|--|
| CON_POLL_A | 1b | binary | 1 bit | 1b: Poll for NFC-A Technology 0b: Do not poll for NFC-A Technology |
| CON_POLL_B | 0b or 1b, see Appendix B | binary | 1 bit | 1b: Poll for NFC-B Technology 0b: Do not poll for NFC-B Technology |
| CON_POLL_F | 1b | binary | 1 bit | 1b: Poll for NFC-F Technology 0b: Do not poll for NFC-F Technology |
| CON_POLL_P | 0b | binary | 1 bit | 1b: Poll for Proprietary Technology 0b: Do not poll for Proprietary Technology |
| CON_BAIL_OUT_A | 1b | binary | 1 bit | 1b: Bail-out after NFC-A 0b: No Bail-out after NFC-A |
| CON_BAIL_OUT_B | 1b | binary | 1 bit | 1b: Bail-out after NFC-B 0b: No Bail-out after NFC-B |

Table 7: Collision Resolution Activity – Symbol 2 – Configuration Parameters

| Name | Symbol 2 Value | Format | Size | Description |
|-------------------|----------------------------|---------------|-------------|--|
| CON_DEVICES_LIMIT | UU, defined in [ICS] | Hexadecimal | 1 byte | <p>CON_DEVICES_LIMIT = 00h: No identifier has to be resolved when a collision is detected.</p> <p>CON_DEVICES_LIMIT > 00h: Number of resolved NFCIDx device identifiers beyond which the collision resolution process can stop resolving when collisions are still pending.</p> |
| CON_ADV_FEAT | 0b | Binary | 1 bit | <p>0b: Advanced protocol features not activated</p> <p>1b: Advanced protocol features activated</p> |
| CON_ANTICOLL | 1b | Binary | 1 bit | <p>0b: Do not use anti-collision</p> <p>1b: Use anti-collision</p> |

Table 8: Device Activation Activity – Configuration Parameters

| Name | Values | Format | Size | Description |
|----------|-------------------------------------|-------------|---------|---|
| CON_ATR | '00' + '00' + ('00uu00u0')b | Hexadecimal | 3 bytes | ATR_REQ Command parameter Refer to [DIGITAL] (Byte 14 of ATR_REQ) for the coding of byte 1. Refer to [DIGITAL] (Byte 15 of ATR_REQ) for the coding of byte 2. Refer to [DIGITAL] (Byte 16 of ATR_REQ) for the coding of byte 3. |
| CON_GB | 'U...U' 0 or more bytes | Hexadecimal | n bytes | General bytes of the ATR_REQ or Higher Layer INF of ATTRIB Refer to [DIGITAL]. Byte 17+n of ATR_REQ) and [DIGITAL]. Byte 10+n for ATTRIB For the ATR_REQ, these bytes contain the General Bytes (G₁ ... G_n) as information for LLCP. For ATTRIB, these bytes contain High Layer INF. |
| CON_RATS | 8' + ('uuuu')b | Hexadecimal | 1 byte | RATS Command Parameters Refer to [DIGITAL] (Byte 2 of RATS Command) for the coding of byte 1. |

| Name | Values | Format | Size | Description |
|------------------|------------------------|-------------|---------|---|
| CON_ATTRIB | '00 08 01' | hexadecimal | 3 bytes | ATTRIB Command Parameters Refer to [DIGITAL] (Byte 6 of ATTRIB Command) for the coding of byte 1. Refer to [DIGITAL] (Byte 7 of ATTRIB Command) for the coding of byte 2. Refer to [DIGITAL] (Byte 8 of ATTRIB Command) for the coding of byte 3 |
| CON_BITR_NFC_DEP | 0 (default value) 3 | Integer | 1 byte | Desired bit rate: 0: maintain the bit rate 1: 106 kbps 2: 212 kbps 3: 424 kbps Refer to Appendix B. |

Table 9: Test Profile – Configuration Parameters

| Parameters | Values |
|-----------------------|--|
| PATTERN_NUMBER | 0000h (default value) |
| T4AT_NFC-DEP_PRIORITY | Values 0b or 1b, defined in [IXIT] |
| NFC-F_BITRATE | 0b: 212 kbps (default value) 1b: 424 kbps |
| REACTIVATION | Values 0b or 1b, defined in [IXIT] |

4.3 Poll Mode Resolution Process

The Poll Mode Resolution Process uses subroutines to improve readability. All routines and subroutines described in the following sections include:

- The flowchart describing the routine or subroutine
- The requirement table related to the routine or subroutine

Each activity is indicated with its name and the related symbol in the flowchart.

4.3.1 Poll Mode Resolution Process – Main Flow

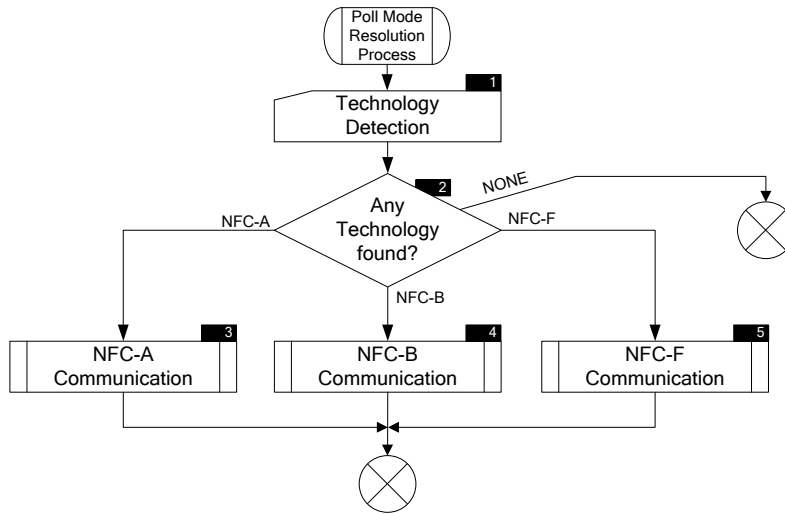

Figure 4: Test Profile – Poll Mode Resolution Process Flowchart – Main Flow

Requirements 3: Test Profile - Poll Mode Resolution Process – Main Flow

| | |
|---------|--|
| 4.3.1.1 | <p>Symbol 1:</p> <p>The NFC Forum Device MUST execute the Technology Detection Activity using the parameters in Table 6 (see [ACTIVITY]).</p> <p>The NFC Forum Device MUST send NFC-F frames using the bit rate indicated in Appendix B.</p> |
| 4.3.1.2 | <p>Symbol 2:</p> <p>If the NFC Forum Device has detected a Technology, then:</p> <ul style="list-style-type: none"> • If NFC-A Technology (i.e., FOUND_A has a value equal to 1), then the NFC Forum Device MUST proceed to Symbol 3. • If NFC-B Technology (i.e., FOUND_B has a value equal to 1), then the NFC Forum Device MUST proceed to Symbol 4. • If NFC-F Technology (i.e., FOUND_F has a value equal to 1), then the NFC Forum Device MUST proceed to Symbol 5. <p>In any other case, the NFC Forum Device MUST exit.</p> |
| 4.3.1.3 | <p>Symbol 3:</p> <p>The NFC Forum Device MUST execute the NFC-A Communication (see Section 4.3.2).</p> |
| 4.3.1.4 | <p>Symbol 4:</p> <p>The NFC Forum Device MUST execute the NFC-B Communication (see Section 4.3.3).</p> |
| 4.3.1.5 | <p>Symbol 5:</p> <p>The NFC Forum Device MUST execute the NFC-F Communication (see Section 4.3.4).</p> |

4.3.2 NFC-A Communication

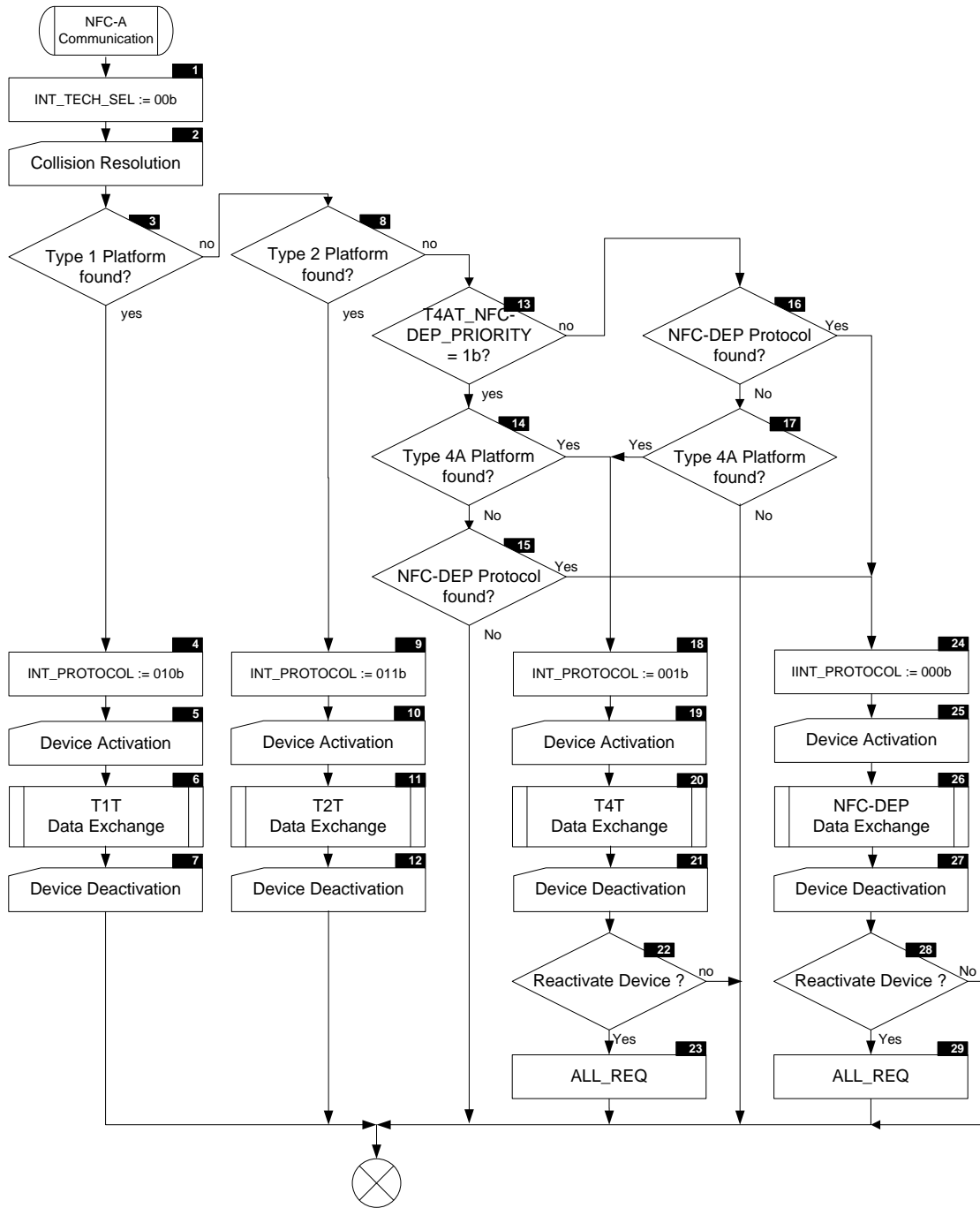

Figure 5: Test Profile – Poll Profile Resolution Process Flowchart – NFC-A Communication

Requirements 4: Test Profile – Poll Profile Resolution Process – NFC-A Communication

| | |
|----------|--|
| 4.3.2.1 | <p>Symbol 1:</p> <p>The NFC Forum Device MUST set INT_TECH_SEL to 00b.</p> |
| 4.3.2.2 | <p>Symbol 2:</p> <p>The NFC Forum Device MUST execute the Collision Resolution Activity using the parameters in Table 7 (see [ACTIVITY]).</p> |
| 4.3.2.3 | <p>Symbol 3:</p> <p>If the NFC Forum Device has found a Type 1 Platform, then the NFC Forum Device MUST proceed to Symbol 10.</p> <p>Otherwise, the NFC Forum Device MUST proceed to Symbol 4.</p> <p>The NFC Forum Device has found a Type 1 Platform when the SENS_RES is a Valid Response and indicates Type 1 Tag platform with b5-b1 of byte 1 equal to 00000b.</p> |
| 4.3.2.4 | <p>Symbol 4:</p> <p>The NFC Forum Device MUST set INT_PROTOCOL to 010b.</p> |
| 4.3.2.5 | <p>Symbol 5:</p> <p>The NFC Forum Device MUST execute the Device Activation Activity using the parameters in Table 8 (see [ACTIVITY]).</p> |
| 4.3.2.6 | <p>Symbol 6:</p> <p>The NFC Forum Device MUST execute the T1T Data Exchange (see Section 4.3.5).</p> |
| 4.3.2.7 | <p>Symbol 7:</p> <p>The NFC Forum Device MUST execute the Device Deactivation Activity (see [ACTIVITY]).</p> |
| 4.3.2.8 | <p>Symbol 8:</p> <p>If the NFC Forum Device has found a Type 2 Platform, then the NFC Forum Device MUST proceed to Symbol 11.</p> <p>Otherwise, the NFC Forum Device MUST proceed to Symbol 5.</p> <p>The NFC Forum Device has found a Type 2 Platform when the SEL_RES Response is a Valid Response and indicates Type 2 Tag platform with b7-b6 equal to 00b.</p> |
| 4.3.2.9 | <p>Symbol 9:</p> <p>The NFC Forum Device MUST set INT_PROTOCOL to 011b.</p> |
| 4.3.2.10 | <p>Symbol 10:</p> <p>The NFC Forum Device MUST execute the Device Activation Activity using the parameters in Table 8 (see [ACTIVITY]).</p> |
| 4.3.2.11 | <p>Symbol 11:</p> <p>The NFC Forum Device MUST execute the T2T Data Exchange (see Section 4.3.6).</p> |

| | |
|----------|--|
| 4.3.2.12 | <p>Symbol 12:</p> <p>The NFC Forum Device MUST execute the Device Deactivation Activity (see [ACTIVITY]).</p> |
| 4.3.2.13 | <p>Symbol 13:</p> <p>If the NFC Forum Device gives priority to Type 4A Platform (i.e., T4AT_NFC-DEP_PRIORITY has a value equal to 1b), then the NFC Forum Device MUST proceed to Symbol 7.</p> <p>Otherwise, the NFC Forum Device MUST proceed to Symbol 6.</p> |
| 4.3.2.14 | <p>Symbol 14:</p> <p>If the NFC Forum Device has found a Type 4A Platform, then the NFC Forum Device MUST proceed to Symbol 12.</p> <p>Otherwise, the NFC Forum Device MUST proceed to Symbol 9.</p> <p>The NFC Forum Device has found a Type 4A Platform when the SEL_RES Response is a Valid Response and indicates Type 4A Tag platform compliant with [ISO/IEC_14443] with b6 equal to 1b.</p> |
| 4.3.2.15 | <p>Symbol 15:</p> <p>If the NFC Forum Device has found NFC-DEP, then the NFC Forum Device MUST proceed to Symbol 13.</p> <p>Otherwise, the NFC Forum Device MUST exit.</p> <p>The NFC Forum Device has found an NFC-DEP Protocol when the SEL_RES Response is a Valid Response and indicates NFC-DEP Protocol with b7 equal to 1b.</p> |
| 4.3.2.16 | <p>Symbol 16:</p> <p>If the NFC Forum Device has found NFC-DEP, then the NFC Forum Device MUST proceed to Symbol 13.</p> <p>Otherwise, the NFC Forum Device MUST proceed to Symbol 8.</p> <p>The NFC Forum Device has found an NFC-DEP Protocol when the SEL_RES Response is a Valid Response and indicates NFC-DEP Protocol with b7 equal to 1b.</p> |
| 4.3.2.17 | <p>Symbol 17:</p> <p>If the NFC Forum Device has found a Type 4A Platform , then the NFC Forum Device MUST proceed to Symbol 12.</p> <p>Otherwise, the NFC Forum Device MUST exit.</p> <p>The NFC Forum Device has found a Type 4A Platform when the SEL_RES Response is a Valid Response and indicates Type 4A Tag platform compliant with [ISO/IEC_14443] with b6 equal to 1b.</p> |
| 4.3.2.18 | <p>Symbol 18:</p> <p>The NFC Forum Device MUST set INT_PROTOCOL to 001b.</p> |
| 4.3.2.19 | <p>Symbol 19:</p> <p>The NFC Forum Device MUST execute the Device Activation Activity using the parameters in Table 8 (see [ACTIVITY]).</p> |

| | |
|----------|---|
| 4.3.2.20 | Symbol 20: The NFC Forum Device MUST execute the T4T Data Exchange (see Section 4.3.8). |
| 4.3.2.21 | Symbol 21: The NFC Forum Device MUST execute the Device Deactivation Activity (see [ACTIVITY]). |
| 4.3.2.22 | Symbol 22: If REACTIVATION is equal to 1b and PATTERN_NUMBER indicates reactivation (see Appendix B), then the NFC Forum Device MUST proceed to Symbol 28. Otherwise, the NFC Forum Device MUST exit. |
| 4.3.2.23 | Symbol 23: The NFC Forum Device MUST send an ALL_REQ Command and it MUST wait for a Response afterward as defined in [DIGITAL]. |
| 4.3.2.24 | Symbol 24: The NFC Forum Device MUST set INT_PROTOCOL to 000b. |
| 4.3.2.25 | Symbol 25: The NFC Forum Device MUST execute the Device Activation Activity using the parameters in Table 8 (see [ACTIVITY]). |
| 4.3.2.26 | Symbol 26: The NFC Forum Device MUST execute the NFC-DEP Data Exchange (see Section 4.3.9). |
| 4.3.2.27 | Symbol 27: The NFC Forum Device MUST execute the Device Deactivation Activity (see [ACTIVITY]). |
| 4.3.2.28 | Symbol 28: If REACTIVATION is equal to 1b and PATTERN_NUMBER indicates reactivation (see Appendix B), then the NFC Forum Device MUST proceed to Symbol 29. Otherwise, the NFC Forum Device MUST exit. |
| 4.3.2.29 | Symbol 29: The NFC Forum Device MUST send an ALL_REQ Command and it MUST wait for a Response afterward as defined in [DIGITAL]. |

4.3.3 NFC-B Communication

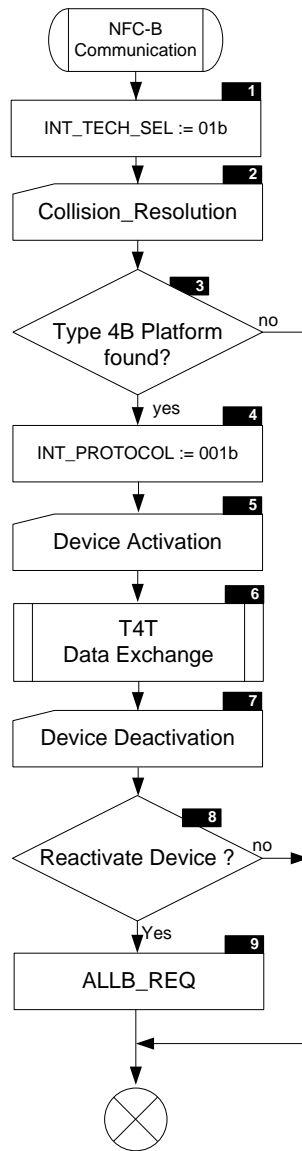

Figure 6: Test Profile – Poll Profile Resolution Process Flowchart – NFC-B Communication

Requirements 5: Test Profile – Poll Profile Resolution Process – NFC-B Communication

| | |
|---------|---|
| 4.3.3.1 | <p>Symbol 1:</p> <p>The NFC Forum Device MUST set INT_TECH_SEL to 01b.</p> |
| 4.3.3.2 | <p>Symbol 2:</p> <p>The NFC Forum Device MUST execute the Collision Resolution Activity using the parameters in Table 7 (see [ACTIVITY]).</p> |
| 4.3.3.3 | <p>Symbol 3:</p> <p>If the NFC Forum Device has found a Type 4B Platform , then the NFC Forum Device MUST proceed to Symbol 4.</p> <p>Otherwise, the NFC Forum Device MUST exit.</p> <p>The NFC Forum Device has found a Type 4B Platform when the SENSB_RES Response is a Valid Response and indicates support for [ISO/IEC_14443] by setting bit b1 of Protocol_Type to 1b.</p> |
| 4.3.3.4 | <p>Symbol 4:</p> <p>The NFC Forum Device MUST set INT_PROTOCOL to 001b.</p> |
| 4.3.3.5 | <p>Symbol 5:</p> <p>The NFC Forum Device MUST execute the Device Activation Activity using the parameters in Table 8 (see [ACTIVITY]).</p> |
| 4.3.3.6 | <p>Symbol 6:</p> <p>The NFC Forum Device MUST execute the T4T Data Exchange (see Section 4.3.8).</p> |
| 4.3.3.7 | <p>Symbol 7:</p> <p>The NFC Forum Device MUST execute the Device Deactivation Activity (see [ACTIVITY]).</p> |
| 4.3.3.8 | <p>Symbol 8:</p> <p>If REACTIVATION is equal to 1b and PATTERN_NUMBER indicates reactivation (see Appendix B), then the NFC Forum Device MUST proceed to Symbol 9.</p> <p>Otherwise, the NFC Forum Device MUST exit.</p> |
| 4.3.3.9 | <p>Symbol 9:</p> <p>The NFC Forum Device MUST send an ALLB_REQ Command and it MUST wait for a Response afterward as defined in [DIGITAL].</p> |

4.3.4 NFC-F Communication

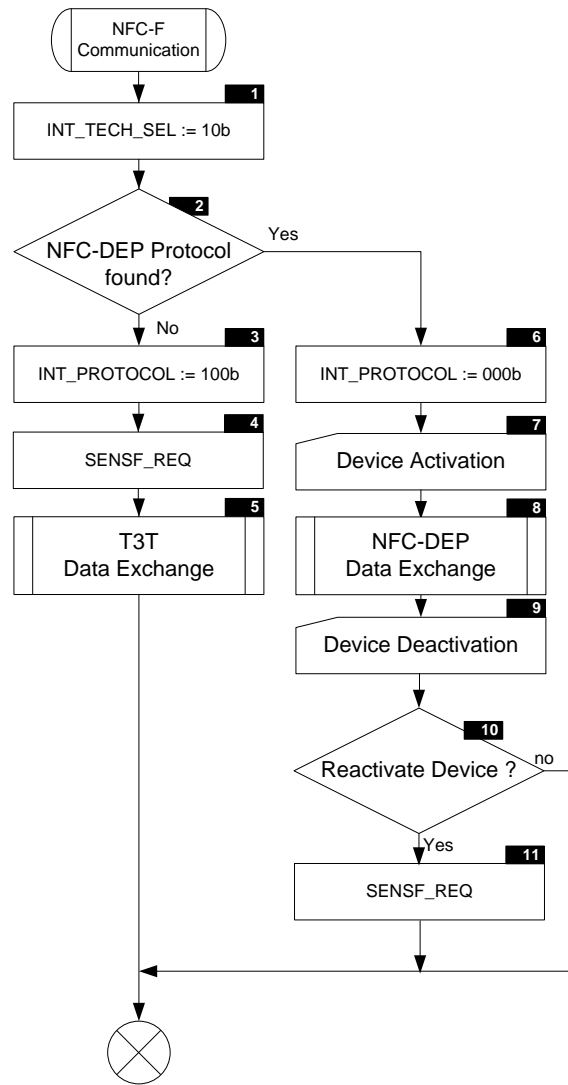

Figure 7: Test Profile – Poll Profile Resolution Process Flowchart – NFC-F Communication

Requirements 6: Test Profile – Poll Profile Resolution Process – NFC-F Communication

| | |
|----------|---|
| 4.3.4.1 | <p>Symbol 1:</p> <p>The NFC Forum Device MUST set INT_TECH_SEL to 10b.</p> |
| 4.3.4.2 | <p>Symbol 2:</p> <p>If the NFC Forum Device has found NFC-DEP, then the NFC Forum Device MUST proceed to Symbol 6.</p> <p>Otherwise, the NFC Forum Device MUST proceed to Symbol 3.</p> <p>The NFC Forum Device has found an NFC-DEP Protocol when the SENSF_RES Response is a Valid Response and indicates support for NFC-DEP Protocol by setting Bytes 1-2 of NFCID2 to 01FEh.</p> |
| 4.3.4.3 | <p>Symbol 3:</p> <p>The NFC Forum Device MUST set INT_PROTOCOL to 100b.</p> |
| 4.3.4.4 | <p>Symbol 4:</p> <p>The NFC Forum Device MUST send a SENSF_REQ Command using the parameters in Appendix B and it MUST wait for a Response afterward as defined in [DIGITAL].</p> |
| 4.3.4.5 | <p>Symbol 5:</p> <p>The NFC Forum Device MUST execute the T3T Data Exchange (see Section 4.3.7).</p> |
| 4.3.4.6 | <p>Symbol 6:</p> <p>The NFC Forum Device MUST set INT_PROTOCOL to 000b.</p> |
| 4.3.4.7 | <p>Symbol 7:</p> <p>The NFC Forum Device MUST execute the Device Activation Activity using the parameters in Table 8 (see [ACTIVITY]).</p> |
| 4.3.4.8 | <p>Symbol 8:</p> <p>The NFC Forum Device MUST execute the NFC-DEP Data Exchange (see Section 4.3.9).</p> |
| 4.3.4.9 | <p>Symbol 9:</p> <p>The NFC Forum Device MUST execute the Device Deactivation Activity (see [ACTIVITY]).</p> |
| 4.3.4.10 | <p>Symbol 10:</p> <p>If REACTIVATION is equal to 1b and PATTERN_NUMBER indicates reactivation (see Appendix B), then the NFC Forum Device MUST proceed to Symbol 11.</p> <p>Otherwise, the NFC Forum Device MUST exit.</p> |
| 4.3.4.11 | <p>Symbol 11:</p> <p>The NFC Forum Device MUST send a SENSF_REQ Command using the parameters in Appendix B and it MUST wait for a Response afterward as defined in [DIGITAL].</p> |

4.3.5 T1T Data Exchange

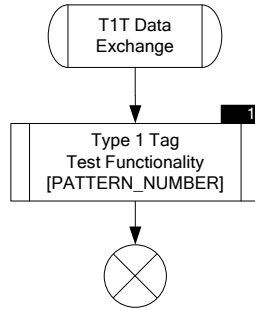

Figure 8: Test Profile – Poll Profile Resolution Process Flowchart – T1T Data Exchange

Requirements 7: Test Profile – Poll Profile Resolution Process – T1T Data Exchange

4.3.5.1 Symbol 1:
 The NFC Forum Device **MUST** execute the Type 1 Tag Test Functionality related to the PATTERN_NUMBER value (see Section 5.3).

4.3.6 T2T Data Exchange

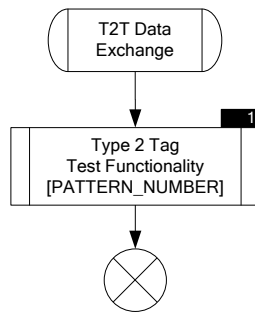

Figure 9: Test Profile – Poll Profile Resolution Process Flowchart – T2T Data Exchange

Requirements 8: Test Profile – Poll Profile Resolution Process – T2T Data Exchange

4.3.6.1 Symbol 1:
 The NFC Forum Device **MUST** execute the Type 2 Tag Test Functionality related to the PATTERN_NUMBER value (see Section 5.4).

4.3.7 T3T Data Exchange

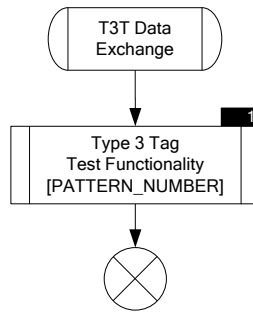

Figure 10: Test Profile – Poll Profile Resolution Process Flowchart – T3T Data Exchange

Requirements 9: Test Profile – Poll Profile Resolution Process – T3T Data Exchange

4.3.7.1 Symbol 1:

The NFC Forum Device **MUST** execute the Type 3 Tag Test Functionality related to the PATTERN_NUMBER value (see Section 5.5).

4.3.8 T4T Data Exchange

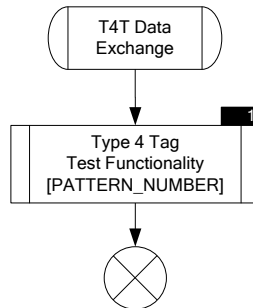

Figure 11: Test Profile – Poll Profile Resolution Process Flowchart – T4T Data Exchange

Requirements 10: Test Profile – Poll Profile Resolution Process – T4T Data Exchange

4.3.8.1 Symbol 1:

The NFC Forum Device **MUST** execute the Type 4 Tag Test Functionality related to the PATTERN_NUMBER value (see Section 5.6).

4.3.9 NFC-DEP Data Exchange

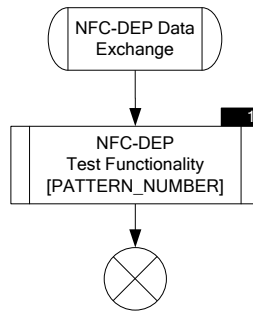

Figure 12: Test Profile – Poll Profile Resolution Process Flowchart – NFC-DEP Data Exchange

Requirements 11: Test Profile – Poll Profile Resolution Process – NFC-DEP Data Exchange

4.3.9.1 Symbol 1:

The NFC Forum Device **MUST** execute the NFC-DEP Test Functionality related to the PATTERN_NUMBER value (see Section 5.2).

4.4 Listen Mode

Requirements 12: Listen Mode

| | |
|---------|--|
| 4.4.1.1 | If the NFC Forum Device remains in the NO_REMOTE_FIELD State (see [ACTIVITY]) for time t_{LM} , then the NFC Forum Device MUST exit from Listen Mode. |
| 4.4.1.2 | If the NFC Forum Device enters into the CARD_EMULATION_4A State (see [ACTIVITY]), then the NFC Forum Device MUST execute the Type 4 Tag Test Functionality in Listen Mode (see Section 6.4). |
| 4.4.1.3 | If the NFC Forum Device enters into the CARD_EMULATION_4B State (see [ACTIVITY]), then the NFC Forum Device MUST execute the Type 4 Tag Test Functionality in Listen Mode(see Section 6.4). |
| 4.4.1.4 | If the NFC Forum Device enters into the CARD_EMULATION_3 State (see [ACTIVITY]), then the NFC Forum Device MUST execute the Type 3 Tag Test functionality in Listen Mode (see Section 6.3). |
| 4.4.1.5 | If the NFC Forum Device enters into the TARGET_A State (see [ACTIVITY]), then the NFC Forum Device MUST execute the NFC-DEP Test Functionality in Listen Mode (see Section 6.2). |
| 4.4.1.6 | If the NFC Forum Device enters into the TARGET_F State (see [ACTIVITY]), then the NFC Forum Device MUST execute the NFC-DEP Test Functionality in Listen Mode (see Section 6.2). |
| 4.4.1.7 | After the NFC Forum Device has concluded the state machine due to No Remote Field Sensed and not in state NO_REMOTE_FIELD , the NFC Forum Device MUST stay in Listen Mode and set the state machine to NO_REMOTE_FIELD for at least t_{RLM} . Refer to Appendix B for the value of t_{RLM} . |
| 4.4.1.8 | If CON_LISTEN_DEP_F=1 and CON_LISTEN_T3TP =1 the NFC Forum Device MUST respond with multiple SENSF_RES in response to a SENSF_REQ . |

NOTE **t_{LM}** value is indicated in [IXIT].

4.5 Exception Processing

Requirements 13: Exception Processing

| | |
|---------|---|
| 4.5.1.1 | If not otherwise specified in this document, [ACTIVITY], or [DIGITAL], if there is a Protocol Error, Timeout Error, Transmission Error, or PROTOCOL EXCEPTION, the NFC Forum Device MUST exit the Poll Mode Resolution Process (see Section 4.1). |
|---------|---|

5 Test Transaction Functionalities in Poll Mode

The NFC Forum Digital Test method is based on the [ISO/IEC_9646] remote test method (see [ISO/IEC_9646-1] and [ISO/IEC_9646-2]), where the existing protocol between the IUT and the Lower Tester (i.e., the protocol to be tested) also conveys the TMPDU (Test Management PDU).

5.1 Test Architecture in Poll Mode

For Poll Mode Testing, a Lower Tester (LT) is presented to the IUT (see Figure 2). The LT stores a set of predefined responses to the commands of the Poll Mode Resolution Process (see Section 4) for each test scenario. The LT sends the responses of the set to the IUT according to the running test scenario. These responses are sent using parameters and timings defined for each Test Case scenario in the Test Case description.

During the execution of a test scenario, the DTA-IUT sends Commands as indicated in the Poll Mode Resolution Process (see Section 4).

When the Poll Mode Resolution Process is running, the LT sends test-specific responses to the DTA-IUT according to the applied test scenario.

As soon as the DTA enters a Test Functionality (see Section 4.3.5, Section 4.3.6, Section 4.3.7, Section 4.3.8, and Section 4.3.9), the DTA-IUT sends commands as described in Section 5.2, Section 5.3, Section 5.4, Section 5.5, and Section 5.6.

The following sections describe Poll Mode functionality.

5.1.1 Loop-back Test Functionality in Poll Mode

Loop-back Functionality is used for testing Type 4A and 4B Tag Half-duplex Protocol and NFC-DEP Protocol (see [DIGITAL]). Loop-back Functionality is used with slight variations in Section 5.2.2 and Section 5.6.2.

This Loop-back Functionality converts each received response into the next command and sends this command back to the LT via the IUT.

The following steps and Figure 13 describe Loop-back Test Functionality.

1. After the DTA enters the Loop-back Test Functionality, the DTA sends the 1st Command Payload.
2. The 1st Command Payload is encapsulated by the transport communication into command(s) sent from the DTA-IUT to the LT.
3. After receiving the command(s), the LT answers with Response(s) to the DTA-IUT.
4. Responses are decapsulated into Response Payloads and sent from the IUT to the DTA.
5. The DTA collects one or more Response Payloads and converts them into one or more Command Payloads to be sent by the IUT encapsulated as Commands to the LT.

Steps 2 to 5 are repeated continuously until the LT indicates with a specific Response to quit Loop-back Test Functionality or until the LT stops responding.

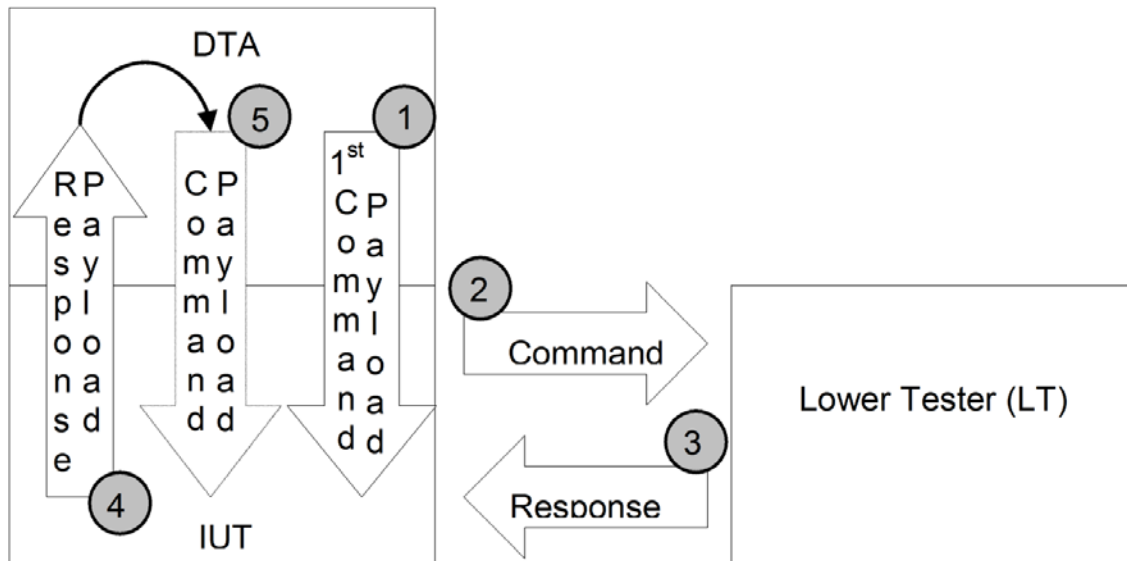

Figure 13: Loop-back Test Functionality in Poll Mode

5.1.2 Type Tag Platform Test Functionality in Poll Mode

Type Tag Platform Test Functionality is used for testing the Type Tag Command Set (see [DIGITAL]). In particular, the Type Tag Platform Test Functionality is used with slight variations in Sections 5.4.2, 5.5.2, 5.5.3.

Type Tag Platform Test Functionality stores test scenarios that are described by predefined commands sets. When the Type Tag Platform Test Functionality is executed, DTA-IUT sends the commands, one after the other, to the LT. The LT sends responses using parameters and timings defined for each Test Case scenario in the Test Case description.

The following steps and Figure 14 describe Type Tag Platform Test Functionality.

1. After the DTA enters the Type Tag Platform Test Functionality, the DTA sends a Command according to the stored Test Scenario to the IUT.
2. The Command is sent from the IUT to the LT.
3. After receiving the Command, the LT answers with a Response to the DTA-IUT according to the applied Test Scenario.
4. The Response is sent to the DTA.

Steps 1 to 4 are repeated continuously until either the Test Scenario stored in the DTA is brought to an end or the LT stops responding.

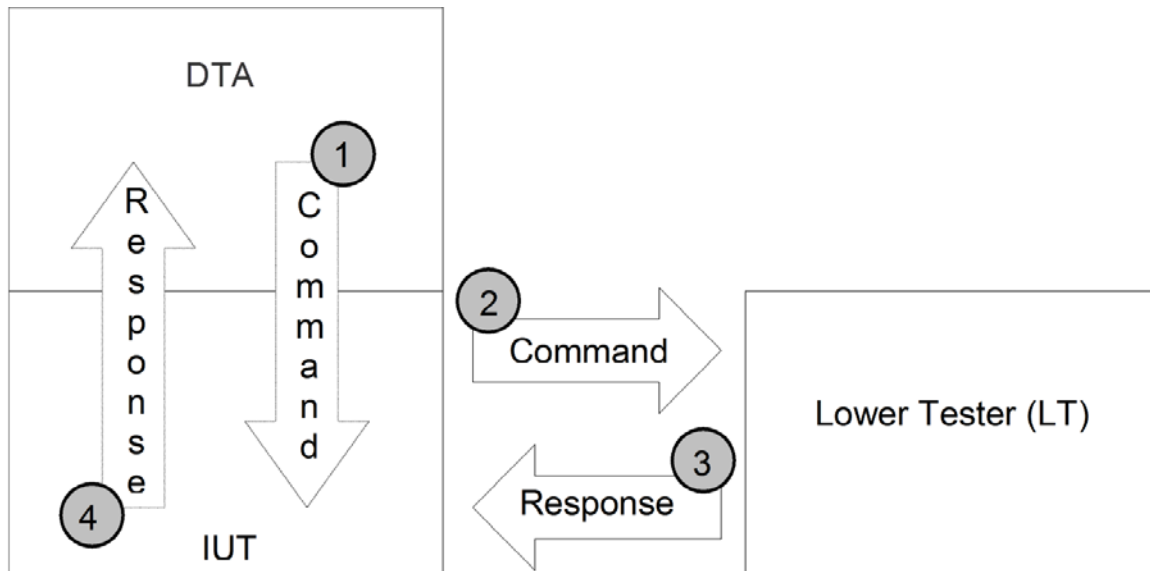

Figure 14: Type Tag Platform Test Functionality in Poll Mode

5.1.3 Type Tag Operation Test Functionality in Poll Mode

Type Tag Operation Test Functionality is used for testing the Type Tag Operation Technical Specifications (see [T1TOP], [T2TOP], [T3TOP], and [T4TOP]). In particular, the Type Tag Test Functionalities are used in Section 5.3.3, Section 5.3.4, Section 5.3.5, Section 5.4.3, Section 5.4.4, Section 5.4.5, Section 5.5.5, Section 5.5.6, Section 5.6.3, and Section 5.6.4.

Type Tag Test Functionality is called from the DTA to the IUT. Three Type Tag Test Functionalities are defined:

- NDEF Read Test Functionality
- NDEF Write Test Functionality
- Transition from READ/WRITE to READ-ONLY Functionality (only applicable to Type 1 Tag Operation and Type 2 Tag Operation)

The following steps and Figure 15 describe the Type Tag Operation Test Functionality.

1. After the DTA enters the Type Tag Operation Test Functionality, the DTA calls a Type Tag Operation Test Functionality.
2. The IUT sends a Command from the IUT to the LT according to the specified Type Tag Operation Test Functionality.
3. After receiving the Command, the LT answers with a Response to the DTA-IUT according to the applied Test Scenario.

Steps 2 to 3 are repeated until Type Tag Operation Test Functionality is completed or the LT stops responding.

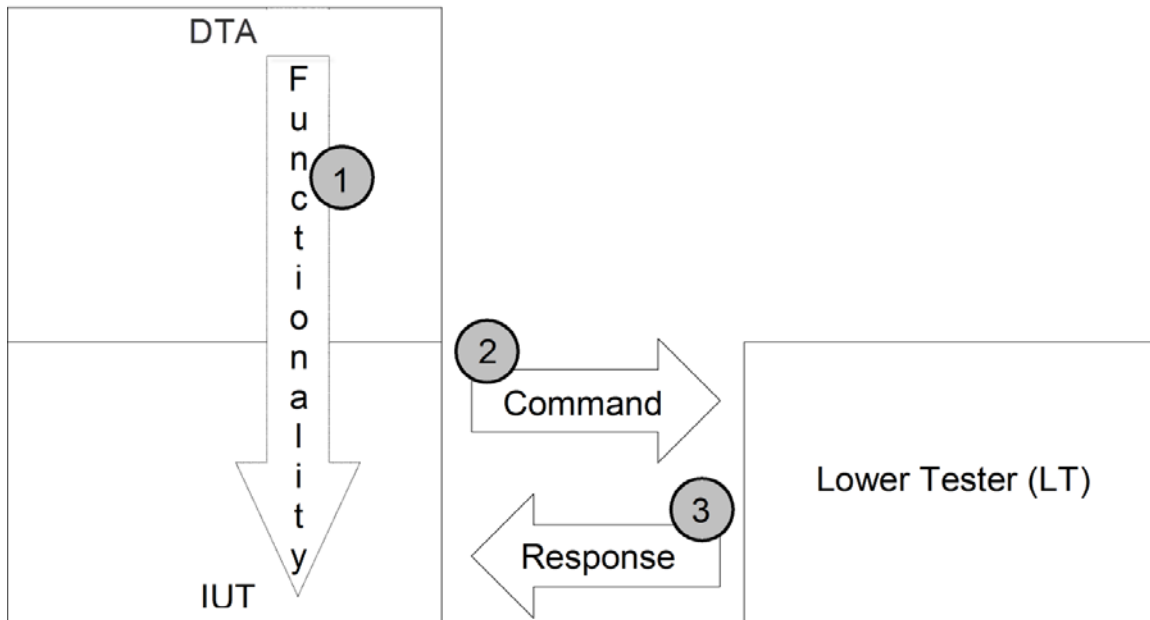

Figure 15: Type Tag Operation Test Functionality in Poll Mode

5.2 NFC-DEP Test Functionality in Poll Mode

This section describes the different NFC-DEP Test Functionalities.

5.2.1 NFC-DEP Test Functionality PATTERN_NUMBER Value

Requirements 14: Type 2 Tag Test Functionalities

5.2.1.1 The NFC Forum Device MUST execute NFC_DEP Test Functionality according to the PATTERN_NUMBER value in Appendix B.

For example, if the PATTERN_NUMBER value is equal to 0000h, the NFC Forum Device executes the NFC-DEP Loop-back Functionality (see Section 5.2.2 and Appendix B).

5.2.2 NFC-DEP Loop-back Functionality in Poll Mode

The NFC-DEP Loop-back Functionality exchanges Application Data with the LT. The Application Data is encapsulated in the Transport Data Bytes of the Data Exchange Protocol Requests/Responses (DEP_REQ/DEP_RES) when transmitted between DTA-IUT and LT.

The Application Data can be transported in two or more chained DEP_RES or DEP_REQ by using a Chaining mechanism (see [DIGITAL] for details on the Chaining mechanism).

NOTE If the IUT reports a failure at the protocol level (protocol error or excess of transmission or time-out errors), see Section 4.5.

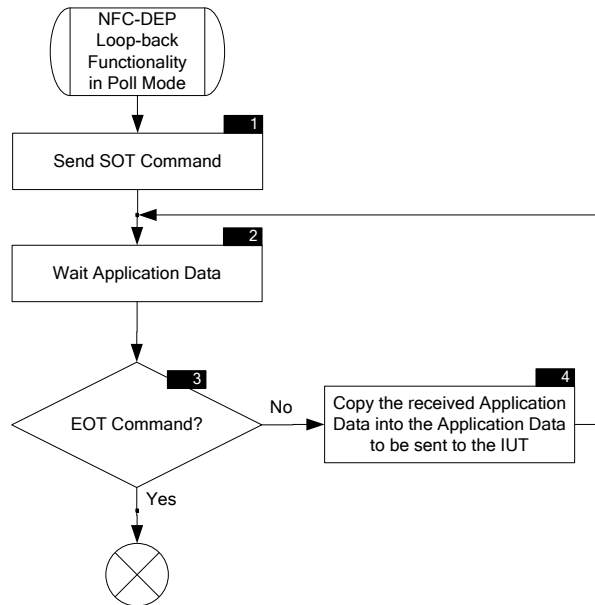

Figure 16: NFC-DEP Loop-back Functionality in Poll Mode Flowchart

Requirements 15: NFC-DEP Loop-back Functionality in Poll Mode

| | |
|---------|---|
| 5.2.2.1 | <p>Symbol 1:</p> <p>The NFC Forum DTA MUST send the Start Of Test Command (SOT), which is the first Application Data. The Start Of Test Command is '00 40 00 01 10 02 01 0E' (Parameter Exchange PDU of LLCP).</p> |
| 5.2.2.2 | <p>Symbol 2:</p> <p>The NFC Forum DTA MUST wait for Application Data sent by the LT in the DEP_RES Response.</p> |
| 5.2.2.3 | <p>Symbol 3:</p> <p>The NFC Forum DTA MUST check the received Application Data.</p> <ul style="list-style-type: none"> • If the Application Data is an End Of Test (EOT) Command encoded as 'FF FF FF 01 01', then execute Device Deactivation Activity with DSL_REQ Command (see [ACTIVITY]). • If the Application Data is an End Of Test (EOT) Command encoded as 'FF FF FF 01 02', then the NFC Forum DTA MUST end the NFC-DEP Loop-back Functionality and execute Device Deactivation Activity with RLS_REQ Command (see [ACTIVITY]). • Otherwise, the NFC Forum DTA MUST proceed to Symbol 4. |
| 5.2.2.4 | <p>Symbol 4:</p> <p>The NFC Forum DTA MUST copy the received Application Data into the next Application Data to be sent to the IUT.</p> |

5.3 Type 1 Tag Test Functionality in Poll Mode

This section describes the different Type 1 Tag Test Functionalities.

5.3.1 Type 1 Tag Test Functionality PATTERN_NUMBER Value

Requirements 16: Type 1 Tag Test Functionalities

| | |
|---------|--|
| 5.3.1.1 | The NFC Forum Device MUST execute Type 1 Tag Test Functionality according to the PATTERN_NUMBER value in Appendix B. |
|---------|--|

For example, if the PATTERN_NUMBER value is equal to 0001h, the NFC Forum Device executes the functionality suitable for both the Type 1 Tag Platform Test Functionality (see Section 5.3.2) and the Type 1 Tag Operation NDEF Read Test Functionality (see Section 5.3.3 and Appendix B).

5.3.2 Type 1 Tag Platform Test Functionality

Use the Type 1 Tag Operation NDEF Read Test Functionality (Section 5.3.3) for the Type 1 Tag Platform in Poll Mode Digital Tests.

5.3.3 Type 1 Tag Operation NDEF Read Test Functionality

Requirements 17: Type 1 Tag Operation NDEF Read Test Functionality

| | |
|---------|---|
| 5.3.3.1 | The NFC Forum Device MUST execute NDEF Read Procedure according to the Type 1 Tag Operation (see [T1TOP], Section 6). |
|---------|---|

| | |
|---------|---|
| 5.3.3.2 | The NFC Forum Device MUST keep the NDEF Message read using the NDEF Read Procedure. |
|---------|---|

| | |
|--|--|
| <i>This requirement is related to Requirement 5.3.4.2 to allow a kind of loopback in the Type Tag Operation doing an NDEF Read test and an NDEF Write test sequentially. This allows testing that an NDEF message is correctly read and written.</i> | |
|--|--|

The command sequence expected from the IUT during the NDEF Read Procedure is described in [IXIT].

The command sequence starts after the response to the RID command is correctly received by the IUT:

1. See [IXIT] for next command.
2. See [IXIT] for command sequence.
3. Etc.
4. See [IXIT] for last command.

5.3.4 Type 1 Tag Operation NDEF Write Test Functionality

Requirements 18: Type 1 Tag Operation NDEF Write Test Functionality

| | |
|---------|---|
| 5.3.4.1 | The NFC Forum Device MUST execute NDEF Write Procedure according to the Type 1 Tag Operation (see [T1TOP], Section 6). |
| 5.3.4.2 | The NFC Forum Device MUST write the NDEF Message previously read using the Type 1 Tag Operation NDEF Read Test Functionality (see Section 5.3.3). |

The command sequence expected from the IUT during the NDEF Write Procedure is described in [IXIT]. The command sequence starts after the response to the RID command is correctly received by the IUT:

1. See [IXIT] for next command.
2. See [IXIT] for command sequence.
3. Etc.
4. See [IXIT] for last command.

5.3.5 Type 1 Tag Operation Transition from READ/WRITE to READ-ONLY Functionality

Requirements 19: Type 1 Tag Operation Transition from READ/WRITE to READ-ONLY Functionality

| | |
|---------|---|
| 5.3.5.1 | The NFC Forum Device MUST execute the Transition from READ/WRITE to READ-ONLY according to the Type 1 Tag Operation (see [T1TOP], Section 6). |
|---------|---|

The command sequence expected from the IUT during the Transition from READ/WRITE to READ-ONLY Procedure is described in [IXIT].

The command sequence starts after the response to the RID command is correctly received by the IUT:

1. See [IXIT] for next command.
2. See [IXIT] for command sequence.
3. Etc.
4. See [IXIT] for last command.

5.4 Type 2 Tag Test Functionality in Poll Mode

This section describes the different Type 2 Tag Test Functionalities.

5.4.1 Type 2 Tag Test Functionality PATTERN_NUMBER Value

Requirements 20: Type 2 Tag Test Functionalities

| | |
|---------|--|
| 5.4.1.1 | The NFC Forum Device MUST execute Type 2 Tag Test Functionality according to the PATTERN_NUMBER value in Appendix B. |
|---------|--|

For example, if the PATTERN_NUMBER value is equal to 0000h, the NFC Forum Device executes the T2T Platform Test Functionality (see Section 5.4.2 and Appendix B).

5.4.2 T2T Platform Test Functionality

Requirements 21: Type 2 Tag Platform Test Functionality

| | |
|---------|--|
| 5.4.2.1 | The NFC Forum Device MUST execute NDEF Write Procedure according to the Type 2 Tag Operation (see [T2TOP], Section 6.4.3). |
| 5.4.2.2 | The NFC Forum Device MUST write the default NDEF Message. |
| 5.4.2.3 | The NFC Forum Device MUST generate a default NDEF message with a number of bytes bigger than 1004. |

The command sequence expected from the IUT during the NDEF Write Procedure is described in [IXIT].

The command sequence starts after the response to the SEL_RES command is correctly received by the IUT:

1. See [IXIT] for next command.
2. See [IXIT] for command sequence.
3. Etc.
4. See [IXIT] for last command.

NOTE Use the same Type 2 Tag Operation NDEF Write Test Functionality for the Type 2 Tag Platform in Poll Mode Digital Tests.

5.4.3 Type 2 Tag Operation NDEF Read Test Functionality

Requirements 22: Type 2 Tag Operation NDEF Read Test Functionality

| | |
|---------|---|
| 5.4.3.1 | The NFC Forum Device MUST execute NDEF Read Procedure according to the Type 2 Tag Operation (see [T2TOP], see Section 6.4.2). |
| 5.4.3.2 | The NFC Forum Device MUST keep the NDEF Message read using the NDEF Read Procedure. |

This requirement is related with the requirement 5.4.4.2 to allow a kind of loopback in the Type Tag Operation doing sequentially an NDEF Read test and an NDEF Write test. This allows testing that an NDEF message is correctly read and written.

The command sequence expected from the IUT during the NDEF Read Procedure is described in [IXIT].

The command sequence starts after the response to the SEL_RES command is correctly received by the IUT:

1. See [IXIT] for next command.
2. See [IXIT] for command sequence.
3. Etc.
4. See [IXIT] for last command.

5.4.4 Type 2 Tag Operation NDEF Write Test Functionality

Requirements 23: Type 2 Tag Operation NDEF Write Test Functionality

| | |
|---------|---|
| 5.4.4.1 | The NFC Forum Device MUST execute NDEF Write Procedure according to the Type 2 Tag Operation (see [T2TOP], Section 6.4.3). |
| 5.4.4.2 | The NFC Forum Device MUST write the NDEF Message previously read using the Type 2 Tag Operation NDEF Read Test Functionality (see Section 5.4.3), |

The command sequence expected from the IUT during the NDEF Write Procedure is described in [IXIT].

The command sequence starts after the response to the SEL_RES command is correctly received by the IUT:

1. See [IXIT] for next command.
2. See [IXIT] for command sequence.
3. Etc.
4. See [IXIT] for last command.

5.4.5 Type 2 Tag Operation Transition from READ/WRITE to READ-ONLY Functionality

Requirements 24: Type 2 Tag Operation Transition from READ/WRITE to READ-ONLY Functionality

5.4.5.1 The NFC Forum Device MUST execute Transition from READ/WRITE to READ-ONLY according to the Type 2 Tag Operation (see [T2TOP], Section 6.4.4.2).

The command sequence expected from the IUT during the Transition from READ/WRITE to READ-ONLY Procedure is described in [IXIT].

The command sequence starts after the response to the SEL_RES command is correctly received by the IUT:

1. See [IXIT] for next command.
2. See [IXIT] for command sequence.
3. Etc.
4. See [IXIT] for last command.

5.5 Type 3 Tag Test Functionality in Poll Mode

This section describes the different Type 3 Tag Test Functionalities.

5.5.1 Type 3 Tag Test Functionality PATTERN_NUMBER Value

Requirements 25: Type 3 Tag Test Functionalities

5.5.1.1 The NFC Forum Device MUST execute Type 3 Tag Test Functionality according to the PATTERN_NUMBER value in Appendix B.

For example, if the PATTERN_NUMBER value is equal to 0003h, the NFC Forum Device executes the Type 3 Tag Operation Command Test with Minimum Number of Blocks (see Section 5.5.2 and Appendix B).

5.5.2 Type 3 Tag Operation Command Test with Minimum Number of Blocks

For the T3T Platform in Poll Mode Digital Tests, the Type 3 Tag Operation Command Test with Minimum Number of Blocks can be used.

In this case, the IUT sends the commands (called command sequences) one after the other to the LT using the 2-Bytes Block List Format (see [T3TOP], Section 5.5). The LT sends responses using parameters and timings as defined for each Test Case scenario in the Test Case description.

The interface between DTA and IUT depends on the device, and one or more exchanges may be performed.

The Type 3 Tag Operation Command Test with Minimum Number of Blocks requires a specific command sequence between IUT and LT. The command sequence starts after the IUT correctly receives the response to the SENSF_RES command (see Section 4.3.4).

1. The IUT sends the UPDATE Command with the 2-Bytes Block List format:
 '08' + 'XX XX XX XX XX XX XX XX'(IDm) + '01'(Number of Services) + '09 00'(Service Code List) + '01'(Number of Blocks) + '80 01'(Block List) + 'XX...XX'(16 bytes of Block Data)
2. The LT replies with the UPDATE Response. See [IXIT], Section 4.8.1.
3. The IUT sends CHECK Command with 2-Bytes Block List format:
 '06' + 'XX XX XX XX XX XX XX XX'(IDm) + '01'(Number of Services) + '09 00'(Service Code List) + '01'(Number of Blocks) + '80 01'(Block List)
4. The LT replies with the CHECK Response. See [IXIT], Section 4.8.1.
5. The IUT sends the EOT Command. See [IXIT], Section 4.8.1.

The Commands related to items 2, 4, and 5 are indicated in detail in [IXIT].

EOT Command is the UPDATE Command with the specific parameter defined in the scenario. The purpose of EOT Command is to acknowledge to LT that the test has correctly finished.

NOTE If the LT received the EOT Command, the LT should decide that the test has correctly finished.

5.5.3 Type 3 Tag Operation Command Test with Maximum Number of Services

For the T3T Platform in Poll Mode Digital Tests, the Type 3 Tag Operation Command Test with Maximum Number of Services can be used.

In this case, the IUT sends the commands (called command sequences) one after the other to the LT using the 2-Bytes Block List Format (see [T3TOP], Section 5.5). The LT sends responses using parameters and timings as defined for each Test Case scenario in the Test Case description.

The interface between DTA and IUT depends on the device, and one or more exchanges may be performed.

The Type 3 Tag Operation Command Test with Maximum Number of Services requires a specific command sequence between IUT and LT. The command sequence starts after the IUT correctly receives the response to the SENSF_RES command (see Section 4.3.4).

1. The IUT sends the UPDATE Command with 2-Bytes Block List format:
 '08' + 'XX XX XX XX XX XX XX XX'(IDm) + '0C'(Number of Services) + '09 00 49 11 89 22 C9 33 09 44 49 55 89 66 C9 77 09 88 49 99 89 AA C9 BB'(Service Code List) + '0C'(Number of Blocks) + '80 00 81 00 82 00 83 00 84 00 85 00 86 00 87 00 88 00 89 00 8A 00 8B 00'(Block List) + 'XX...XX'(192 Bytes of Block Data)
2. The LT replies with the UPDATE Response. See [IXIT], Section 4.8.2.
3. The IUT sends CHECK Command with 2-Bytes Block List format:

'06' + 'XX XX XX XX XX XX XX XX'(IDm) + '0F'(Number of Services) + '0B 00 4B 11 8B 22 CB 33 0B 44 4B 55 8B 66 CB 77 0B 88 4B 99 8B AA CB BB 0B CC 4B DD 8B EE'(Service Code List) + '0F'(Number of Blocks) + '80 00 81 00 82 00 83 00 84 00 85 00 86 00 87 00 88 00 89 00 8A 00 8B 00 8C 00 8D 00 8E 00'(Block List)

4. The LT replies with the CHECK Response. See [IXIT], Section 4.8.2.

5. The IUT sends the EOT Command. See [IXIT], Section 4.8.2.

The Commands related to items 2, 4, and 5 are indicated in detail in the [IXIT].

EOT Command is the UPDATE Command with the specific parameter defined in the scenario. The purpose of EOT Command is to acknowledge to LT that the test has correctly finished.

NOTE If the LT received the EOT Command, the LT should decide that the test has correctly finished.

5.5.4 Type 3 Tag Operation Command Test with Maximum Number of Blocks

For the T3T Platform in Poll Mode Digital Tests, the Type 3 Tag Operation Command Test with Maximum Number of Blocks can be used.

In this case, the IUT sends the commands (called command sequences) one after the other to the LT using the 2-Byte and 3-Bytes Block List Format (see [T3TOP], Section 5.5). The LT sends responses using parameters and timings as defined for each Test Case scenario in the Test Case description.

The interface between DTA and IUT depends on the device. One or more exchanges may be performed.

The Type 3 Tag Operation Command Test with Maximum Number of Blocks requires a specific command sequence between IUT and LT. The command sequence starts after the IUT correctly receives the response to the SENSF_RES command (see Section 4.3.4).

1. The IUT sends the UPDATE Command with 2-Bytes Block List format:

'08' + 'XX XX XX XX XX XX XX XX'(IDm) + '04'(Number of Services) + '09 00 49 11 89 22 C9 33'(Service Code List) + '0D'(Number of Blocks) + '80 00 80 01 80 02 81 00 81 01 81 02 82 00 82 01 82 02 83 00 83 01 83 02 83 03'(Block List) + 'XX...XX'(208 Bytes of Block Data)

2. The LT replies with the UPDATE Response. See [IXIT], Section 4.8.3.

3. The IUT sends CHECK Command with 2-Bytes Block List format:

'06' + 'XX XX XX XX XX XX XX XX'(IDm) + '05'(Number of Services) + '0B 00 4B 11 8B 22 CB 33 0B 44'(Service Code List) + '0F'(Number of Blocks) + '80 00 80 01 80 02 81 00 81 01 81 02 82 00 82 01 82 02 83 00 83 01 83 02 84 00 84 01 84 02'(Block List)

4. The LT replies with the CHECK Response. See [IXIT], Section 4.8.3.

5. The IUT sends the UPDATE Command with 3-Bytes Block List format:

'08' + 'XX XX XX XX XX XX XX XX'(IDm) + '07'(Number of Services) + '09 00 49 11 89 22 C9 33 09 44 49 55 89 66'(Service Code List) + '0C'(Number of Blocks) + '00 00 00 00 01 00 01 00 00 01 01 00 02 00 00 02 01 00 03 00 00 03 01 00 04 00 00 04 01 00 05 00 00 06 00 00'(Block List) + 'XX...XX'(192 Bytes of Block Data)

6. The LT replies with the UPDATE Response. See [IXIT], Section 4.8.3.
7. The IUT sends the CHECK Command with 3-Bytes Block List format:
 '06' + 'XX XX XX XX XX XX XX XX'(IDm) + '05'(Number of Services) + '0B 00 4B 11
 8B 22 CB 33 0B 44'(Service Code List) + '0F'(Number of Blocks) + '00 00 00 00 01 00 00 02
 00 01 00 00 01 01 00 01 02 00 02 00 00 02 01 00 02 02 00 03 00 00 03 01 00 03 02 00 04 00
 00 04 01 00 04 02 00'(Block List)
8. The LT replies with the CHECK Response. See [IXIT], Section 4.8.3.
9. The IUT sends the EOT Command. See [IXIT], Section 4.8.3.

The Commands related to items 2, 4, 6, 8, and 9 are indicated in detail in [IXIT].

EOT Command is the UPDATE Command with the specific parameter defined in the scenario. The purpose of EOT Command is to acknowledge to LT that the test is correctly finished.

NOTE If the LT received EOT Command, the LT should decide that the test has correctly finished.

5.5.5 Type 3 Tag Operation NDEF Read Test Functionality

Requirements 26: Type 3 Tag Operation NDEF Read Test Functionality

- | | |
|---------|---|
| 5.5.5.1 | The NFC Forum Device MUST execute NDEF Read Procedure according to the Type 3 Tag Operation (see [T3TOP], Section 6.4.2). |
|---------|---|

The command sequence expected from the IUT during the NDEF Read Procedure is described in the [IXIT].

The command sequence starts after the IUT correctly receives the response to the SENSEF_RES command:

1. The IUT sends the CHECK Command for reading Attribute Information
 '06' + 'XX XX XX XX XX XX XX XX'(IDm) + '01'(Number of Services) + '0B 00'(Service Code List) + '01'(Number of Blocks) + '80 00'(Block List)
2. See [IXIT] for changing the command sequence to read 240 Bytes NDEF Data.

5.5.6 Type 3 Tag Operation NDEF Write Test Functionality

Requirements 27: Type 3 Tag Operation NDEF Write Test Functionality

- | | |
|---------|--|
| 5.5.6.1 | The NFC Forum Device MUST execute NDEF Write Procedure according to the Type 3 Tag Operation (see [T3TOP], Section 6.4.3). |
|---------|--|

The command sequence expected from the IUT during the NDEF Write Procedure is described in the [IXIT].

The command sequence starts after the IUT correctly receives the response to the SENSEF_RES command:

1. The IUT sends the CHECK Command for reading Attribute Information:

'06' + 'XX XX XX XX XX XX XX XX'(IDm) + '01'(Number of Services) + '0B 00'(Service Code List) + '01'(Number of Blocks) + '80 00'(Block List)

2. The LT replies to the CHECK Response. See [IXIT], Section 4.8.5.

3. The IUT sends the UPDATE Command for writing Attribute Information:

'08' + 'XX XX XX XX XX XX XX XX'(IDm) + '01'(Number of Services) + '09 00'(Service Code List) + '01'(Number of Blocks) + '80 00'(Block List) + ' XX XX XX XX XX XX XX XX XX XX 0F XX XX XX XX XX XX'(Attribute Information block)

4. The LT replies UPDATE Response. See [IXIT], Section 4.8.5.

5. See [IXIT] for changing the command sequence to write 192 Bytes NDEF Data.
6. The IUT sends the UPDATE Command for writing Attribute Information
'08' + 'XX XX XX XX XX XX XX XX'(IDm) + '01'(Number of Services) + '09 00'(Service Code List) + '01'(Number of Blocks) + '80 00'(Block List) + ' XX XX XX XX XX XX XX XX XX 00 XX 00 00 C0 XX XX'(Attribute Information block)

5.6 Type 4 Tag Test Functionality in Poll Mode

This section describes the different Type 4 Tag Test Functionalities.

5.6.1 Type 4 Tag Test Functionality PATTERN_NUMBER Value

Requirements 28: Type 4 Tag Test Functionalities

- 5.6.1.1 The NFC Forum Device MUST execute Type 4 Tag Test Functionality according to the PATTERN_NUMBER value in Appendix B.

For example, if the PATTERN_NUMBER value is equal to 0000h, the NFC Forum Device executes Type 4A Tag and Type 4B Tag Loop-back Functionality (see Section 5.6.2 and Appendix B).

5.6.2 Type 4A Tag and Type 4B Tag Loop-back Functionality in Poll Mode

The Type 4A Tag and Type 4B Tag Loop-back Functionality exchanges Application Data with the LT. The Application Data can be divided into Responses (called Response-Application Protocol Data Unit or R-APDU) and Commands (called Command-Application Protocol Data Unit or C-APDU). R-APDU and C-APDU are exchanged between the IUT and the LT and are encapsulated in I-Blocks.

C-APDU and R-APDU can be transported in two or more chained I-Blocks using a Chaining mechanism (see [DIGITAL] for details on the Chaining mechanism).

NOTE If the IUT reports a failure at the protocol level (protocol error or excess of transmission or time-out errors), see Section 4.5.

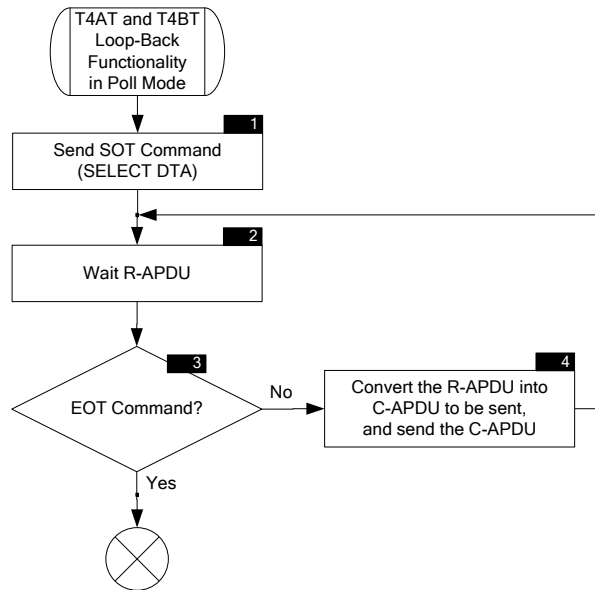

Figure 17: Type 4A Tag and Type 4B Tag Loop-back Functionality in Poll Mode Flowchart

Requirements 29: Type 4A Tag and Type 4B Tag Loop-back Functionality in Poll Mode

| | |
|---------|--|
| 5.6.2.1 | <p>Symbol 1:</p> <p>The NFC Forum DTA MUST send the Start Of Test Command (SOT), which is the first C-APDU from DTA to IUT. The Start Of Test Command (also called SELECT DTA) is:</p> <p>'00 A4 04 00 0E' + "2NFC.SYS.DDF01" + '00' (in hexadecimal format '00 A4 04 00 0E' + '32 4E 46 43 2E 53 59 53 2E 44 44 46 30 31' + '00')</p> |
| 5.6.2.2 | <p>Symbol 2:</p> <p>The NFC Forum DTA MUST wait for R-APDU from the IUT.</p> |
| 5.6.2.3 | <p>Symbol 3:</p> <p>The NFC Forum DTA MUST check the R-APDU.</p> <p>If the R-APDU is an End Of Test Command (EOT Command) encoded as 'FF FF FF 01 01' + '90 00', then the NFC Forum DTA MUST end the Type 4A Tag and Type 4B Tag Loop-back Functionality.</p> <p>Otherwise, the NFC Forum DTA MUST proceed to Symbol 4.</p> |
| 5.6.2.4 | <p>Symbol 4:</p> <p>The NFC Forum DTA MUST convert the R-APDU into the C-APDU to be sent to the IUT and format the C-APDU.</p> <p>Format the R-APDU as Data_R + '90 00' by setting Data_R to a sequence of one or more bytes, up to 256 bytes.</p> <p>Format the C-APDU as Data_C by setting Data_C to a sequence of one or more bytes equal to Data_R in the received R-APDU.</p> |

5.6.3 Type 4 Tag Operation NDEF Read Test Functionality

Requirements 30: Type 4 Tag Operation NDEF Read Test Functionality

| | |
|--|---|
| 5.6.3.1 | The NFC Forum Device MUST execute NDEF Read Procedure according to the Type 4 Tag Operation (see [T4TOP], Section 6.4.2). |
| 5.6.3.2 | The NFC Forum Device MUST keep the NDEF Message read using the NDEF Read Procedure. |
| <i>This requirement is related with the requirement 5.6.4.2 to allow a kind of loopback in the Type Tag Operation doing sequentially an NDEF Read test and an NDEF Write test. This allows testing that an NDEF message is correctly read and written.</i> | |

The command sequence expected from the IUT during the NDEF Read Procedure is described in [IXIT].

The command sequence starts after the IUT correctly receives the response to the ATS command:

1. See [IXIT] for next command.
2. See [IXIT] for command sequence.
3. Etc.
4. See [IXIT] for last command.

5.6.4 Type 4 Tag Operation NDEF Write Test Functionality

Requirements 31: Type 4 Tag Operation NDEF Write Test Functionality

| | |
|---------|---|
| 5.6.4.1 | The NFC Forum Device MUST execute the NDEF Write Procedure according to the Type 4 Tag Operation (see [T4TOP], Section 6.4.3). |
| 5.6.4.2 | The NFC Forum Device MUST write the NDEF Message previously read using the Type 4 Tag Operation NDEF Read Test Functionality (see Section 5.6.3). |

The command sequence expected from the IUT during the NDEF Write Procedure is described in [IXIT].

The command sequence starts after the IUT correctly receives the response to the ATS command:

1. See [IXIT] for next command.
2. See [IXIT] for command sequence.
3. Etc.
4. See [IXIT] for last command.

6 Test Transaction Functionalities in Listen Mode

6.1 Test Architecture in Listen Mode

For Listen Mode Testing, a Lower Tester (LT) is presented to the IUT (see Figure 2). The LT stores a set of predefined commands for each test scenario and sends the commands of the set to the IUT according to the running test scenario. These commands are sent using parameters and timings as defined for each Test Case scenario in the Test Case description.

During the execution of a test scenario, the DTA-IUT sends Responses as indicated in Listen Mode (see Section 4).

When in Listen Mode, the LT sends test-specific commands to the DTA-IUT according to the applied test scenario.

As soon as the DTA enters a Test Functionality in Listen Mode (see Section 4.4), the DTA-IUT sends commands as described in Section 6.2, Section 6.3, and Section 6.4.

The following sections describe Listen Mode functionalities.

6.1.1 Loop-back Test Functionality in Listen Mode

Loop-back Functionality is used for testing Type 4A and 4B Tag Half-duplex Protocol and NFC-DEP Protocol (see [DIGITAL]). Loop-back Functionality is used with slight variations in Section 6.2.2 and Section 6.4.2.

Loop-back Functionality converts each received command into the next response and sends this response back to the LT via the IUT.

The following steps and Figure 18 describe Loop-back Test Functionality.

1. The LT sends a Command to the IUT.
2. Commands are decapsulated into Command Payloads and sent from the IUT to the DTA.
3. The DTA collects one or more Command Payloads and converts them into one or more Response Payloads to be sent by the IUT encapsulated as Responses to the LT.
4. The IUT sends the Response to the LT.

Steps 1 to 4 are repeated continuously until the LT stops sending Commands.

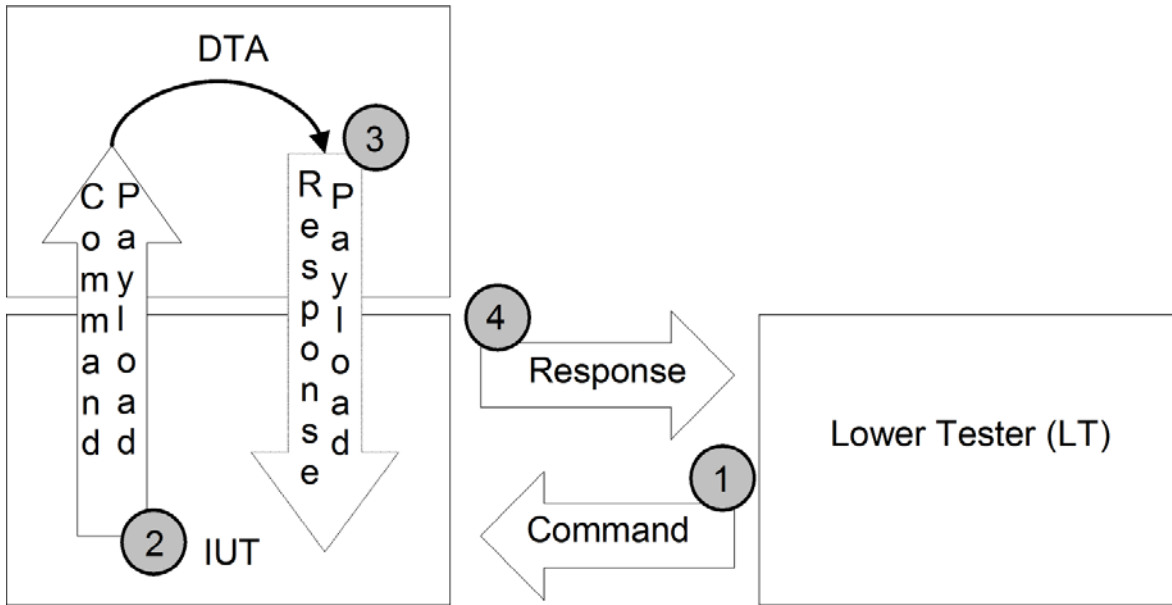

Figure 18: Loop-back Test Functionality in Listen Mode

6.1.2 Type Tag Platform Test Functionality in Listen Mode

Type Tag Platform Test Functionality is used for testing the Type Tag Command Set (see [DIGITAL]). Type Tag Platform Test Functionality is used in Section 6.3.2.

Type Tag Platform Test Functionality stores test scenarios that are described by predefined responses sets. When the Type Tag Platform Test Functionality is executed, DTA-IUT sends the responses, one after the other, to the LT. The LT sends commands using parameters and timings as defined for each Test Case scenario in the Test Case description.

The following steps and Figure 19 describe Type Tag Platform Test Functionality.

1. The LT sends a Command according to the Test Scenario to the IUT.
2. The Command is sent from the IUT to the DTA.
3. After receiving the Command, the DTA answers with a Response to the IUT according to the stored Test Scenario.
4. The Response is sent to the LT.

Steps 1 to 4 are repeated continuously until the LT stops sending Commands.

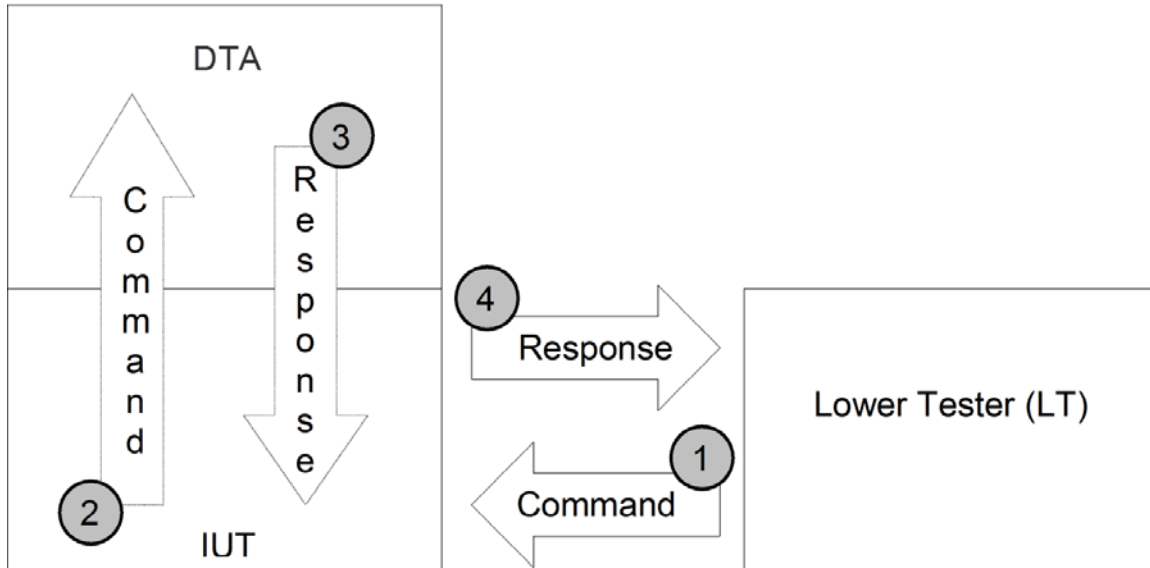

Figure 19: Type Tag Platform Test Functionality in Poll Mode

6.2 NFC-DEP Test Functionality in Listen Mode

This section describes NFC-DEP Test Functionality in Listen Mode.

6.2.1 NFC-DEP Test Functionality Requirement

Requirements 32: NFC-DEP Test Functionality in Listen Mode

6.2.1.1 The NFC Forum Device MUST execute the NFC-DEP Loop-back Functionality in Listen Mode (see Section 6.2.2).

6.2.2 NFC-DEP Loop-back Functionality in Listen Mode

The NFC-DEP Loop-back Functionality exchanges Application Data with the LT. The Application Data is encapsulated in the Transport Data bytes of the Data Exchange Protocol Requests/Responses (DEP_REQ/DEP_RES) when transmitted between DTA-IUT and LT.

The Application Data can be transported in several chained DEP_RES or DEP_REQ by using a Chaining mechanism (see [DIGITAL] for details on the Chaining mechanism).

NOTE If the IUT reports a failure at the protocol level (protocol error or excess of transmission or time-out errors), see Section 4.5.

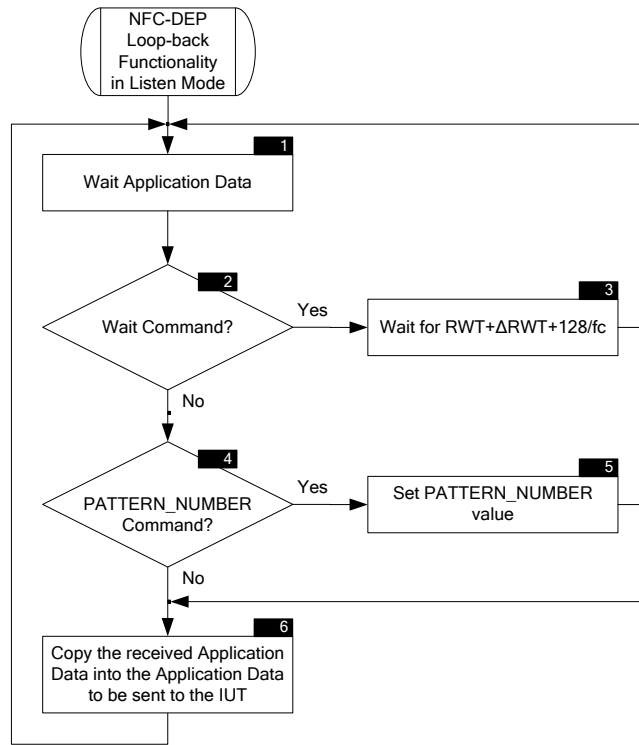

Figure 20: NFC-DEP Loop-back Functionality in Listen Mode Flowchart

Requirements 33: NFC-DEP Loop-back Functionality in Listen Mode

| | |
|---------|--|
| 6.2.2.1 | Symbol 1: The NFC Forum DTA MUST wait for Application Data from the IUT (i.e., data received by the IUT in the DEP_REQ Request). |
| 6.2.2.2 | Symbol 2: If the Application Data is a Wait Command encoded as 'FF FF FF 01 03', then the NFC Forum DTA MUST proceed to Symbol 3. Otherwise, the NFC Forum DTA MUST proceed to Symbol 4. |
| 6.2.2.3 | Symbol 3: The NFC Forum DTA MUST copy the received Application Data into the next Application Data to be sent to the IUT. |
| 6.2.2.4 | Symbol 4: The NFC Forum DTA MUST check the received Application Data. <ul style="list-style-type: none"> • If the Application Data is a PATTERN_NUMBER Command encoded as 'FF00 0000 XXXX', then the NFC Forum DTA MUST proceed to Symbol 5. • Otherwise, the NFC Forum DTA MUST proceed to Symbol 6. |
| 6.2.2.5 | Symbol 5: The NFC Forum DTA SHALL set the PATTERN_NUMBER value equal to 'XXXX' (last 2 bytes of the received PATTERN_NUMBER Command). |
| 6.2.2.6 | Symbol 6: The NFC Forum DTA MUST copy the received Application Data into the next Application Data to be sent to the IUT. |

6.3 Type 3 Tag Test Functionality in Listen Mode

This section describes the Type 3 Tag Test Functionality in Listen Mode.

6.3.1 Type 3 Tag Test Functionality Requirement**Requirements 34: Type 3 Tag Test Functionality in Listen Mode**

| | |
|---------|--|
| 6.3.1.1 | The NFC Forum Device MUST execute the Type 3 Tag Basic Command Exchange Test Functionality in Listen Mode (see Section 6.3.2). |
|---------|--|

6.3.2 Type 3 Tag Basic Command Exchange Test Functionality in Listen Mode

For the Type 3 Tag in Listen Mode Digital Tests, the IUT in Listen Mode SHALL send the response when it receives the command from the LT in Poll Mode.

For UPDATE command with 2-byte Block List:

'09' + 'XX XX XX XX XX XX XX XX' (NFCID2) + '00' + '00'

For CHECK command with 2-byte Block List:

'07' + 'XX XX XX XX XX XX XX XX'(NFCID2) + '00' + '00' + '01' + 'XX...XX'(16 bytes of Block Data)

For UPDATE command with 3-byte Block List:

'09' + 'XX XX XX XX XX XX XX XX'(NFCID2) + '00' + '00'

For CHECK command with 3-byte Block List:

'07' + 'XX XX XX XX XX XX XX XX'(NFCID2) + '00' + '00' + '01' + 'XX...XX'(16 bytes of Block Data)

NOTE The Functionality to execute is selected by the LT as indicated in [IXIT].

6.4 Type 4 Tag Test Functionality in Listen Mode

This section describes the Type 4 Tag Test Functionality in Listen Mode.

6.4.1 Type 4 Tag Test Functionality Requirement

Requirements 35: Type 4 Tag Test Functionality in Listen Mode

6.4.1.1 The NFC Forum Device MUST implement either Type 4A Tag and Type 4B Tag Loop-back Functionality in Listen Mode (see Section 6.4.2) or Type 4A Tag and Type 4B Tag Proprietary Functionality in Listen Mode (see Section 6.4.3).
The NFC Forum Device MAY implement both the Type 4A Tag and Type 4B Tag Loop-back Functionality in Listen Mode (see Section 6.4.2), or the Type 4A Tag and Type 4B Tag Proprietary Functionality in Listen Mode (see Section 6.4.3).

NOTE The Functionality to be executed is selected by the LT as indicated in [IXIT].

6.4.2 Type 4A Tag and Type 4B Tag Loop-back Functionality in Listen Mode

The Type 4A Tag and Type 4B Tag Loop-back Functionality exchanges Application Data with the LT. The Application Data can be divided into Responses (called Response-Application Protocol Data Unit or R-APDU) and Commands (called Command-Application Protocol Data Unit or C-APDU). R-APDU and C-APDU are exchanged between the IUT and the LT and are encapsulated in I-Blocks. APDU and R-APDU pairs can be transported in several chained I-Blocks using a Chaining mechanism (refer to [DIGITAL] for details on the Chaining mechanism).

NOTE If the IUT reports a failure at the protocol level (protocol error or excess of transmission or time-out errors), see Section 4.5.

The Type 4A Tag and Type 4B Tag Loop-back Functionality is applied when testing the chaining of the Type 4A and 4B Tag Half-duplex Protocol (see [DIGITAL]).

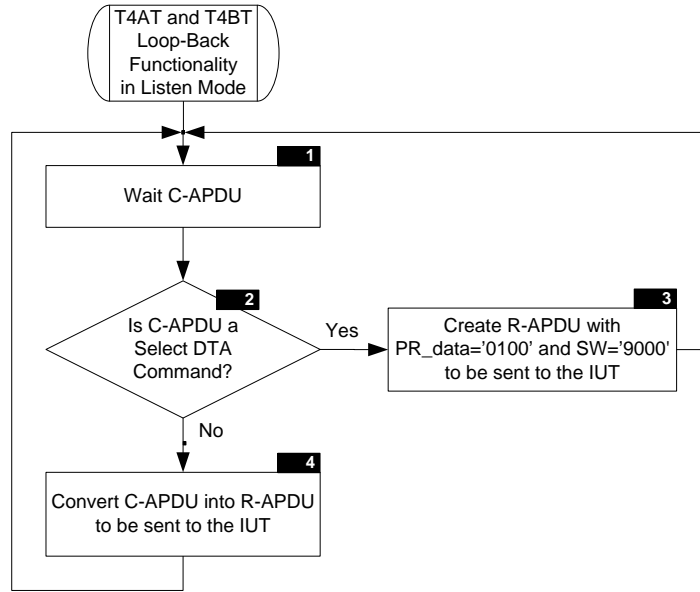

Figure 21: Type 4A Tag and Type 4B Tag Loop-back Functionality in Listen Mode Flowchart

Requirements 36: Type 4A Tag and Type 4B Tag Loop-back Functionality in Listen Mode

| | |
|---------|--|
| 6.4.2.1 | <p>Symbol 1:</p> <p>The NFC Forum DTA MUST wait for C-APDU from the IUT (i.e., data received by the IUT)</p> |
| 6.4.2.2 | <p>Symbol 2:</p> <p>The NFC Forum DTA MUST check the received C-APDU.</p> <ul style="list-style-type: none"> • If the C-APDU is a Select DTA encoded as '00 A4 04 00 0E' + "1NFC.SYS.DDF01" + '00' (in hexadecimal format '00 A4 04 00 0E' + '31 4E 46 43 2E 53 59 53 2E 44 44 46 30 31' + '00'), then the NFC Forum DTA MUST proceed to Symbol 3. • Otherwise, the NFC Forum DTA MUST proceed to Symbol 4. |
| 6.4.2.3 | <p>Symbol 3:</p> <p>The NFC Forum DTA MUST create an R-APDU encoded as '01 00 90 00' (PR_DATA (Proprietary Response Data) equal to '01 00' and SW (Status Word) equal to '90 00') to be sent to the IUT.</p> |
| 6.4.2.4 | <p>Symbol 4:</p> <p>The NFC Forum DTA MUST convert the received C-APDU into the R-APDU to be sent to the IUT.</p> <p>Format the C-APDU as '80 EE 00 00' + Lc + Data_C + '00' with:</p> <ul style="list-style-type: none"> • Lc 1-byte value that depends on Data_C length • Data_C Command Data sequence of one or more bytes up to 250 <p>Format the R-APDU as Data_R + '90 00' with:</p> <ul style="list-style-type: none"> • Data_R Response Data, sequence of one or more bytes equal to the Data_C in the received C-APDU |

6.4.3 Type 4A Tag and Type 4B Tag Proprietary Functionality in Listen Mode

Type 4A Tag and Type 4B Tag Proprietary Functionality exchanges Application Data with the LT. The Application Data can be divided into Responses (called Response-Application Protocol Data Unit or R-APDU) and Commands (called Command-Application Protocol Data Unit or C-APDU). R-APDU and C-APDU are exchanged between the IUT and the LT and are encapsulated in I-Blocks. APDU and R-APDU pairs can be transported in several chained I-Blocks using a Chaining mechanism (see [DIGITAL] for details on the Chaining mechanism).

NOTE If the IUT reports a failure at the protocol level (protocol error or excess of transmission or time-out errors), see Section 4.5.

Requirements 37: Type 4A Tag and Type 4B Tag Proprietary Functionality in Listen Mode – Generic Requirements

| | |
|---------|--|
| 6.4.3.1 | The Type 4A Tag and Type 4B Tag Proprietary Functionality SHALL have a P_AID (Proprietary Application Identifier). The P_AID is contained in the first I-block of the protocol exchange in a Select DTA command with the format of '00 A4 04 00' +Lc + P_AID + Le. |
| 6.4.3.2 | The Type 4A Tag and Type 4B Tag Proprietary Functionality SHALL allow and support a sufficient number of command-and-response pairs to complete the relevant Listen Mode test cases. The minimum number of command- response pairs is three, excluding the Select DTA command. |

The expected response to the Select DTA command and further C-APDU and R-APDU exchange requirements is defined by the IUT manufacturer and can be entered into [IXIT]. This allows the test tool to be pre-configured for a test session performing the required command exchanges and validating the IUT responses. There is no requirement for the P_AID and data for the Proprietary Application in this version of the document.

The example below shows the proprietary command-response exchanges and data that shall be submitted by [IXIT]. In the example, the proprietary application supports minimum requirements such as:

- Responds to a Select Application Command with P_AID
- One initial command-response with two additional command-and-response pairs is also supported (command-and-response data below is not shown but shall be completed in the [IXIT] form).

P_AID (proprietary application Identifier): XX XX XX XX XX XX XX XX XX XX
(n bytes)

Lc: 0n , Le:00

R-APDU for Select Application command: xx.....xx (hex bytes)

C-APDU-init: 80 A8 00 00 XX XX XX XX

R-APDU-init: XX.....XX (hex bytes)

C-APDU-1:00 B2 01 0C 00

R-APDU-1: XX.....XX (hex bytes)

C-APDU-2:00 B2 02 0C 00

R-APDU-2: XX.....XX (hex bytes)

NOTE The hex bytes as well as the 'xx' presentation in the example above may be any value based on the product application supported. Commands and responses can contain the same data value (one command supported by multiple repetitions) in all exchanges above following the Select Application command.

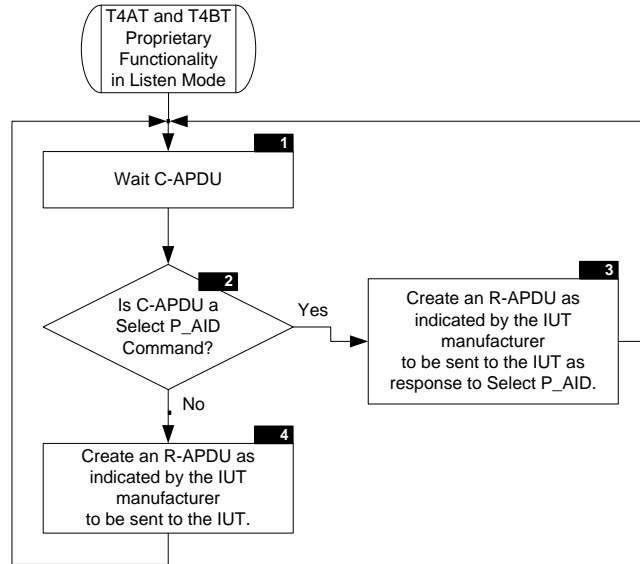

Figure 22: T4AT and T4BT Proprietary Functionality in Listen Mode Flowchart

Requirements 38: T4AT and T4BT Proprietary Functionality in Listen Mode

| | |
|---------|---|
| 6.4.3.3 | <p>Symbol 1:</p> <p>The NFC Forum DTA MUST wait for C-APDU from the IUT (i.e., data received by the IUT).</p> |
| 6.4.3.4 | <p>Symbol 2:</p> <p>The NFC Forum DTA MUST check the received C-APDU.</p> <ul style="list-style-type: none"> • If the C-APDU is a Select P_AID encoded as '00 A4 04 00' +Lc + P_AID + Le, then the NFC Forum DTA MUST proceed to Symbol 3. • Otherwise, the NFC Forum DTA MUST proceed to Symbol 4. |
| 6.4.3.5 | <p>Symbol 3:</p> <p>The NFC Forum DTA MUST create an R-APDU as indicated by the IUT manufacturer in [IXIT] to be sent to the IUT as response to Select P_AID.</p> |
| 6.4.3.6 | <p>Symbol 4:</p> <p>The NFC Forum DTA MUST create an R-APDU as indicated by the IUT manufacturer in [IXIT] to be sent to the IUT.</p> |

A. Exhibit A

No items have been included in Exhibit A.

B. Values

Throughout this document, symbols are used to identify the values of Parameters. The actual values of the Parameters are listed in this Appendix. For some of the Parameters, a minimum and maximum value is defined. Other Parameters are defined by a single value.

Parameters have a value for the NFC Forum Device in Poll Mode and for the NFC Forum Device in Listen Mode. Unless otherwise specified, the value for Poll Mode has to be used when the parameter is referenced in a Poll Mode requirement. The value for Listen Mode has to be used when referenced in a Listen Mode requirement.

B.1 Timing Value

| Parameter | Poll Mode Value | | | Listen Mode Value | | | Units |
|-----------|-----------------|---------|-----|-------------------|---------|-----|-------|
| | Min | Nominal | Max | Min | Nominal | Max | |
| t_{RLM} | | | | 6.0 | | | ms |

C. PATTERN_NUMBER

The table below indicates the functionality or the parameter to be used or to be executed in conjunction with the PATTERN_NUMBER value set at the moment in the DTA.

| PATTERN_NUMBER | CON_POLL_B | CON_BITR_NFC_DEP ¹ | NFC-F_BIT_RATE ² | CON_LISTE_N_DEP_F | CON_LISTE_N_T3TP ³ | SESNF_REQ | SENSF_REQ Reactivation ⁴ | Reactivation | Test Transaction Functionality in | | | | | |
|----------------|------------|-------------------------------|-----------------------------|-------------------|-------------------------------|------------|-------------------------------------|--------------|-----------------------------------|--|--|--------------------------------------|---------------------------|---------------------------------|
| | | | | | | | | | Poll Mode | | | | | Listen Mode |
| | | | | | | | | | NFC-DEP | Type 1 Tag | Type 2 Tag | Type 3 Tag | Type 4 Tag | |
| 0000h | 1 | 0 | 0 | 1 | [ICS] | - | - | No | Loop-back, Section 5.2.2 | - | Platform, Section 5.4.2 | - | Loop-back, Section 5.6.2 | Command Exchange, Section 6.3.1 |
| 0001h | 1 | 0 | 0 | 1 | [ICS] | 12FC,00,00 | - | No | - | NDEF Read, Section 5.3.3 | NDEF Read, Section 5.4.3 | NDEF Read, Section 5.5.5 | NDEF Read, Section 5.6.3 | Command Exchange, Section 6.3.1 |
| 0002h | 1 | 0 | 0 | 1 | [ICS] | 12FC,00,00 | - | No | - | NDEF Write, Section 5.3.4 | NDEF Write, Section 5.4.4 | NDEF Write, Section 5.5.6 | NDEF Write, Section 5.6.4 | Command Exchange, Section 6.3.1 |
| 0003h | 1 | 0 | 0 | 1 | [ICS] | 12FC,00,00 | - | No | - | Transition to READ-ONLY, Section 5.3.5 | Transition to READ-ONLY, Section 5.4.5 | Min Number of Block, Section 5.5.2 | - | Command Exchange, Section 6.3.1 |
| 0004h | 1 | 0 | 0 | 1 | [ICS] | 12FC,00,00 | - | No | - | - | - | Max Number of Service, Section 5.5.3 | - | Command Exchange, Section 6.3.1 |
| 0005h | 1 | 0 | 0 | 1 | [ICS] | 12FC,00,00 | - | No | - | - | - | Max Number of Block, Section 5.5.4 | - | Command Exchange, Section 6.3.1 |
| 0006h | 1 | 0 | 1 | 1 | [ICS] | 12FC,00,00 | - | No | Loop-back, Section 5.2.2 | - | - | Min Number of Block, Section 5.5.2 | - | Command Exchange, Section 6.3.1 |
| 0007h | 1 | 0 | 0 | 1 | [ICS] | FFFF,01,0F | FFFF,00,03 | Yes | Loop-back, Section 5.2.2 | - | - | Min Number of Block, Section 5.5.2 | Loop-back, Section 5.6.2 | Command Exchange, Section 6.3.1 |
| 0008h | 1 | 0 | 1 | 1 | [ICS] | FFFF,01,0F | FFFF,00,03 | NFC-F only | Loop-back, Section 5.2.2 | - | - | Min Number of Block, Section 5.5.2 | - | Command Exchange, Section 6.3.1 |
| 0009h | 1 | 3 | 0 | 1 | [ICS] | - | - | No | Loop-back, Section 5.2.2 | - | - | - | - | Command Exchange, Section 6.3.1 |
| 000Ah | 0 | 0 | 1 | 1 | [ICS] | - | - | No | - | - | - | - | - | Command Exchange, Section 6.3.1 |
| 000Bh | 0 | 0 | 0 | 1 | [ICS] | - | - | No | - | - | - | - | - | Command Exchange, Section 6.3.1 |
| 000Ch | 1 | 0 | 0 | 0 | [ICS] | - | - | No | - | - | - | - | - | Command Exchange, Section 6.3.1 |
| 000Dh | 1 | 0 | 0 | 1 | 0 | - | - | No | - | - | - | - | - | - |

¹ Desired bit rate: 0: maintain the bit rate, 1: 106 kbps, 2: 212 kbps, 3: 424 kbps

² 0b: 212 kbps (default value), 1b: 424 kbps

³ 1b in case the [ICS] indicates support for "Listen for T3T platform", 0b otherwise

⁴ SC,RC,TSN: System Code (SC), Request Code (RC), Time Slot Number (TSN)

⁵ The Type 3 Tag Test Functionality is applicable if CON_LISTEN_T3TP=1

D. Revision History

The following table outlines the revision history of Device Test Application Specification.

Table 10: Revision History

| Document Name | Revision and Release Date | Status | Change Notice | Supersedes |
|---------------------------------------|------------------------------|--------|---|-------------|
| Device Test Application Specification | Version 1.0, July 2010 | Final | | All drafts |
| Device Test Application Specification | Version 1.1, October 2010 | Final | Editorial changes. Moved Pattern number tables to Appendix B to avoid editorial inconsistencies. Added PATTERN_NUMBERS 000Ah and 000Bh for Guard Time Testing | Version 1.0 |
| Device Test Application Specification | Version 1.2, December 2010 | Final | Editorial Changes | Version 1.1 |
| Device Test Application Specification | Version 1.2.2, February 2012 | Final | Added PATTERN_NUMBERS 000Ch and 000Dh for single SENSF_RES. Corrected CON_SENSF_RES format. Modified PATTERN_NUMBER 0006h according to CR#49. | Version 1.2 |